



# Operation Manual

with Maintenance Information

SV06ENS

SV06ENL

SV08ENL

SV08EWL

SV10EWL

## **NOTICE**

Read this manual before operating equipment.



[Original Instructions]

Models Covered: SV06E1NS, SV06E1NL, SV08E1NL,  
SV08E1WL, SV10E1WL

(Commercial Names: SV06ENS, SV06ENL, SV08ENL,  
SV08EWL, SV10EWL)

Serial Number Range: after 779462 – Current

Part Number: GS-439AS

January 2018

**Contact us:**

Head office

**AICHI CORPORATION**

1152 Ryoke Ageo Saitama 362-8550 Japan

TEL: +81-48-781-1111

<http://www.aichi-corp.co.jp>

**Copyright**

© 2017 Aichi Corporation. All rights reserved.

No part of this manual may be reproduced in any form, in an electronic retrieval system or otherwise, without the written permission from AICHI, except for personal use or other cases permitted by copyright laws.

This machine has been manufactured to conform to European Machinery Directive 2006/42/EC and European Standard EN280.



# Important Information

Thank you very much for making your purchase from AICHI.

Please operate and use the machine correctly.

- Operation of the machine is to be done in accordance with this manual. Failure to operate, inspect and maintain the machine correctly and in accordance with this manual may lead to death or serious injury, or damage to the machine or other property.
- Read, understand and follow the instructions in this manual before using, inspecting or maintaining the machine.
- Read, understand, and obey all applicable employer and job site safety rules, and local, state, and federal laws, rules, and regulations.
- Not all accidents or incidents are foreseeable, and thus, cannot be addressed in this manual. Therefore, the machine must be operated by following safe practices, and by using caution, common sense and good judgment to control the machine at all times.
- Operators of the machine must be qualified, trained and certified to operate the machine.
- The machine is designed to lift people and equipment. It is designed for use in assembly and repair work in high places (work on ceilings, roofs, buildings, etc.). It is strictly prohibited to use the machine for other purposes.
- To the full extent permitted by law, and without prejudice to any other exclusions of liability under any contract for supply of the machine, AICHI does not accept responsibility for injury, death, damages, direct or indirect loss, or other expenses incurred due to abuse, alteration, or improper use of the machine, including failure to follow the safety guidance provided in this manual.
- Proper maintenance must be done including the replacement of parts that are worn out or have reached the end of their service lives. Refer to the separate service manual and follow the replacement standards of that manual. Contact AICHI or an AICHI dealer to do the replacement.
- Use only AICHI's genuine spare parts to replace those parts that affect the safety and stability of the machine.
- It is strictly forbidden to make modifications to the machine without obtaining AICHI's written approval.
- Perform all maintenance described in this manual and in the designated service manual for the machine.
- This manual covers the entire array of options and equipment available with a specific model. There may be explanations in this manual for equipment not specified for your machine.
- All specifications provided in this manual are current at the time of publication. However, continuous product improvement is an AICHI policy, and therefore, product specifications and design are subject to change without notice.
- The illustrations in this manual are intended as representative reference views only. They may depict shapes and equipment that are different than your machine.
- This manual must be kept with the machine and immediately available for use at all times. Keep the manual in the manual holder of the machine.
- When you transfer the use or ownership of the machine, please make sure to leave this manual with the machine.
- The original of this manual is written in English. If this manual is not written in English, it is a translated one. In the event of a discrepancy between the original and translated manuals, the original manual prevails.
- This manual describes the correct operation and handling procedures for the self-propelled vertical aerial platforms:

Commercial Names	Model Codes	Height, Platform Max
SV06ENS	SV06E1NS	5.7 m
SV06ENL	SV06E1NL	6.1 m
SV08ENL	SV08E1NL	7.7 m
SV08EWL	SV08E1WL	7.9 m
SV10EWL	SV10E1WL	9.7 m

## Safety Alert Symbol and Signal Words



This is the safety alert symbol. It is used to alert you to potential personal injury hazards. Obey all safety messages that follow this symbol to avoid possible injury or death.

The signal words, "DANGER," "WARNING," and "CAUTION" identify the degree of hazard and its level of seriousness.



Indicates a hazardous situation which, if not avoided, will result in death or serious injury.



Indicates a hazardous situation which, if not avoided, could result in death or serious injury.



Indicates a hazardous situation which, if not avoided, could result in minor or moderate injury.



Indicates a hazardous situation which, if not avoided, could result in property damage. It may also be used to provide special information to assist in the machine operation.

## Symbols Used in Illustrations



Throughout this manual, you will also see the symbol of a circle with a backslash through it. This means "DO NOT," "DO NOT DO THIS," or "DO NOT LET THIS HAPPEN."

## Owner and User Responsibilities

All owners and users of the machine must read, understand, and comply with all applicable regulations. Ultimate compliance to national safety regulations is the responsibility of the user and their employer.

## Operator Qualifications

Operator of the machine must receive safety training to ensure safe operations. Incorrect use of the machine can cause serious injury or death.

All personnel are requested to receive safety training and only trained and authorized personnel are permitted to operate the machine. This manual should be used in conjunction with safety training. Operator of the machine must not undertake responsibility for the machine operation until enough training has been given by qualified and authorized persons.

## Environmental Protection

Various laws and regulations specify specific procedures for disposing of parts and oil. When disposing of parts or oil yourself, you are responsible for ensuring all actions comply with applicable laws and regulations.

### Considerations before operations

- Look around the machine and confirm the absence of oil or water leaks.  
Oil or water leaking from the machine may cause soil contamination or water pollution if allowed to seep into the ground or waterways. Always collect and wipe up any waste fluids.

### Considerations during operations

- Be considerate towards residents in the vicinity when operating the machine. Take special care with noise and direction of lights at night or early in the morning.

### Considerations for inspections and replacement

- Oil- or grease-soaked rags or other materials used for cleaning or inspection work must be stored in specified locations. Leaving rags or other materials outside after use may result in ground contamination due to rain seepage or fire.
- Old oil, filters, and lamps must be disposed of by a waste disposal contractor after replacement.
- The batteries contain lead and dilute sulfuric acid. Improper disposal will harm the environment. Please contact AICHI or an AICHI dealer to replace batteries.
- Burning old tires produces toxic gases and will harm the environment.  
To replace the tires, contact AICHI or an AICHI dealer. If you wish to dispose of tires yourself, contact a waste disposal contractor.

### Correct disposal of waste materials

- Consult with AICHI or an AICHI dealer to dispose of the machine after a number of years of use.  
Dispose of the machine in the appropriate manner. Improper disposal can be harmful to the environment.
- Dispose of waste such as old tires, batteries, and hydraulic oil appropriately and in compliance with applicable laws and regulations after replacement.

# Table of Contents

<b>Chapter 1 Safety Rules ..... 1</b>	
1. Electrocution Hazards.....1	
2. Tip Over Hazards.....1	
3. Runaway Hazards.....3	
4. Fall Hazards.....3	
5. Collision Hazards.....3	
6. Damaged Machine Hazards.....4	
7. Fire Hazards.....4	
8. Battery Safety.....5	
9. Personal Safety.....5	
<b>Chapter 2 Decals ..... 6</b>	
1. Symbol and Pictorials Definitions .....6	
2. Safety Signs and Locations .....7	
<b>Chapter 3 Safety Systems &amp; Devices..... 13</b>	
1. List of Safety Systems.....13	
2. Safety Prop.....15	
2-1 How to Use Safety Prop.....15	
2-2 Stowing Safety Prop.....15	
<b>Chapter 4 Part Names and Functions..... 16</b>	
1. Part Names of the Machine.....16	
2. Upper Controls.....17	
3. Lower Controls.....19	
<b>Chapter 5 Workplace Check .....21</b>	
<b>Chapter 6 Pre-operation Check .....22</b>	
1. Visual Check.....22	
2. Function Check.....23	
2-1 Preparations for Function Check.....23	
2-2 Battery Level Check.....23	
2-3 Lower Controls Check.....23	
2-4 Natural Descent Check.....24	
2-5 Upper Controls Check.....24	
2-6 Pothole Protector Check.....25	
2-7 Tilt Warning Check.....25	
2-8 Limited Travel Speed Check.....26	
2-9 Last Check.....26	
<b>Chapter 7 Operator Maintenance .....27</b>	
1. Storage Method.....27	
1-1 Detaching Upper Controls.....27	
2. Daily Maintenance.....27	
2-1 Hydraulic Oil Level Check.....27	
2-2 Battery Fluid Level Check.....28	
2-3 Battery Charging.....29	
2-4 After Battery Charging.....30	
2-5 Tires and Wheels Check.....31	
3. Monthly Maintenance.....31	
3-1 Wear Pads Lubrication.....31	
3-2 Pothole Protector Lubrication.....31	
<b>Chapter 8 Operation.....32</b>	
1. Lower Controls (from Ground).....32	
1-1 Raising and Lowering Platform.....32	
2. Upper Controls (from Platform).....33	
2-1 Raising and Lowering Platform.....33	
2-2 Traveling.....34	
2-3 Steering.....35	
3. Extension Deck.....35	
3-1 Extending.....35	
3-2 Retracting.....36	
4. Fold Down Guardrails.....37	
4-1 Folding Down Guardrails.....37	
4-2 Raising Guardrails.....40	
<b>Chapter 9 Emergency Operation.....41</b>	
1. Emergency Stop.....41	
2. Emergency Lowering.....41	
<b>Chapter 10 Transporting .....42</b>	
1. Preparation for Transporting.....42	
2. Loading/Unloading.....43	
3. Tie Down.....43	
4. Hoisting.....44	
5. Lifting with Forklift.....45	
<b>Chapter 11 Storage.....46</b>	
<b>Chapter 12 Troubleshooting.....48</b>	
1. Battery Charger Fault Codes.....48	
2. Diagnostic Codes Chart.....48	
<b>Chapter 13 Specifications.....50</b>	
1. Dimensions.....50	
2. General Specifications.....51	
3. Supplementary Information.....54	

---

<b>Appendix A Test Report .....</b>	<b>55</b>
1. Static Test (EN280; 6.1.4.2.1) .....	55
1-1 SV06ENS.....	55
1-2 SV06ENL.....	55
1-3 SV08ENL.....	55
1-4 SV08EWL.....	55
1-5 SV10EWL.....	55
2. Dynamic Test (EN280; 6.1.4.2.2) .....	56
2-1 SV06ENS.....	56
2-2 SV06ENL.....	56
2-3 SV08ENL .....	56
2-4 SV08EWL .....	56
2-5 SV10EWL .....	56
<b>Appendix B Declaration of Conformity .....</b>	<b>57</b>
<b>Appendix C Daily Inspection Check Sheet ...</b>	<b>59</b>

*This page intentionally left blank.*



# Chapter 1

## Safety Rules

### 1. Electrocution Hazards

#### **⚠ DANGER**

- The machine is not electrically insulated. Do not use the machine near electric power lines.
- Keep a safe distance from electric power lines and apparatus. For safe distance, check your national or local regulations. If no national or local regulation is available, use the table below.

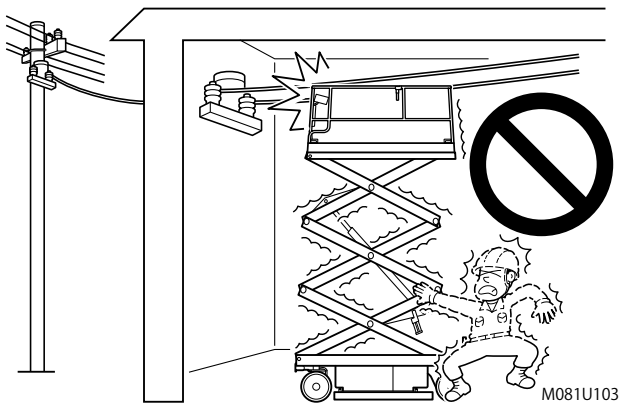

Fig. 1-1

M081U103

**Table 1-1 Minimum Approach Distance**

Voltage (Phase to Phase)	Minimum Approach Distance
0 to 50 kV	3.05 m
over 50 kV to 200 kV	4.60 m
over 200 kV to 350 kV	6.10 m
over 350 kV to 500 kV	7.62 m
over 500 kV to 750 kV	10.67 m
over 750 kV to 1000 kV	13.72 m

- Keep away from the machine if it contacts energized power lines. Until energized power lines are shut down, any persons in the platform must not operate the machine and any persons on the ground must not touch the machine.
- Do not use the machine during lightning or storms. Stop operation in bad weather.
- Do not use the machine as a ground for welding.

### 2. Tip Over Hazards

#### **⚠ DANGER**

- Do not exceed the platform capacity as indicated on the serial number plate.
- Do not put a load that you do not know how heavy it is on the elevated platform.
- Do not hang or attach loads to the machine. Spread loads evenly on the platform.
- Do not use the machine as a crane or lift.

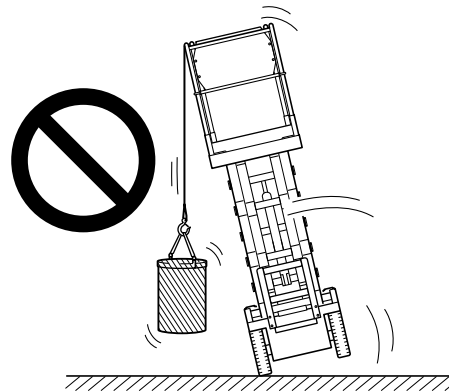

Fig. 1-2

M0852101

- Do not use the machine except on a firm level surface. Always perform workplace checks before moving the machine to the workplace. Do not drive the machine on surfaces with bumps and obstructions or do not attempt to travel over them.

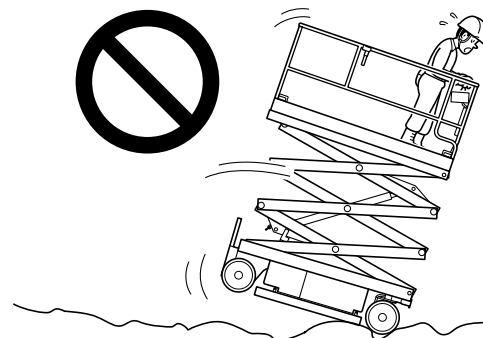

Fig. 1-3

M081U2-3

- Do not use the machine on a moving or mobile surface or vehicle.

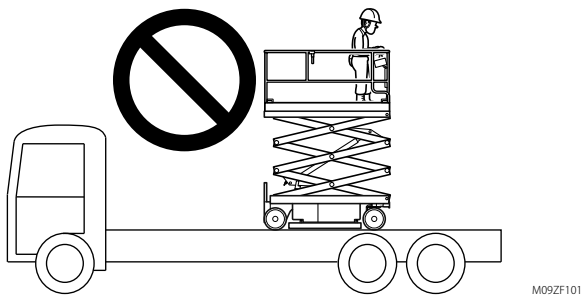

Fig. 1-4

- Do not raise the platform on a slope.
- Do not travel onto a slope with the platform raised.
- When the tilt alarm buzzer sounds, immediately lower the platform and move to a firm level surface. Never continue working after alarm sounds.
- Do not depend on the tilt alarm buzzer as a level indicator. Raise the platform only when the machine is on a firm level surface.
- Do not use a battery that weighs less than the specified battery. The battery also acts as counterweight, so it is essential for the machine stability.

Table 1-2 Battery Weight

Battery	Weight
Trojan T-105	28 kg x 4
Trojan T-125	30 kg x 4
Trojan T-105 AGM	31 kg x 4

- Do not touch or attach the platform to any nearby structures.
- Do not put side loads on the machine.
- Do not push or pull any object outside of the platform.

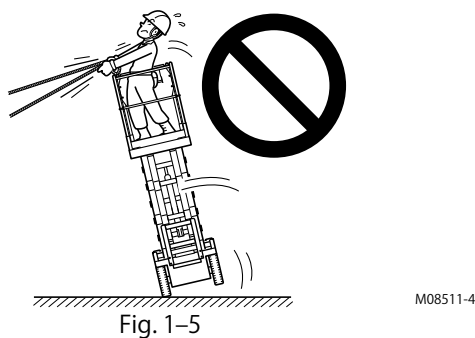

Fig. 1-5

- Do not place ladders, scaffolds or other devices in the platform or against any part of the machine.
- Do not place loads outside of the platform.

- Do not tie down the machine's chassis, scissor arm, or platform to other structures when working.
- Do not raise the platform or operate the machine with the platform elevated in windy or gusty conditions that exceed the limits specified in Table 1-3.

Table 1-3 Maximum Platform Capacities

Model	Total Capacity	Max. Wind Speed
SV06ENS	230 kg	No wind
	1 person	12.5 m/s
SV06ENL	360 kg	No wind
	230kg	1 person
SV08ENL	230 kg	No wind
SV08EWL	450 kg	No wind
	1 person	12.5 m/s
SV10EWL	320 kg	No wind
	1 person	12.5 m/s

- If wind speed exceeds the specified limit when the platform is elevated, lower the platform and do not continue to operate the machine.

The criteria of wind velocity at 10 m above ground are as follows:

Table 1-4 Beaufort Scale (For Reference Only)

Beaufort Number	Wind Speed [m/s]	Ground Conditions
4	5.5-7.9	Raises dust and loose paper; small branches are moved
5	8.0-10.7	Small trees in leaf begin to sway; crested wavelets form on inland waters
6	10.8-13.8	Large branches in motion; whistling heard in telegraph wires; umbrellas used with difficulty
7	13.9-17.1	Whole trees in motion; inconvenience felt when walking against wind

- Do not increase the surface area that can catch wind, such as covering the platform with a sheet. The stability of the machine will decrease.
- Do not use the machine on a slippery or icy surface.
- Do not disable or alter machine components that in any way affect safety and stability.

### 3. Runaway Hazards

- The machine can travel and park only on smooth surfaces which are firm and for which all 4 wheels can maintain contact evenly with the ground.
- Do not drive or park the machine on a slope exceeding the maximum travelable tilt angle.

Table 1-5 Maximum Travelable Tilt Angle

Maximum Travelable Tilt Angle (Stowed)	
Front to Back (Gradeability)	25 % (14 °)
Side to Side (Side Slope)	25 % (14 °)

### 4. Fall Hazards

#### **⚠ DANGER**

- Do not use a ladder or step in the platform.



Fig. 1-6

M0851203

- Do not sit, stand or climb on the guardrails, or jump from the platform to another structure.

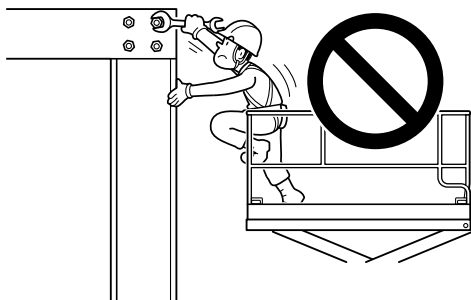

Fig. 1-7

M081U304

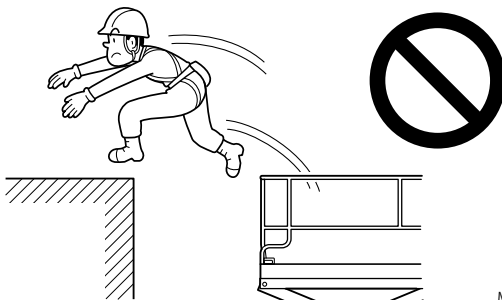

Fig. 1-8

M0851303

- Do not climb up/down from the platform when it is raised.
- Be especially careful when getting on/off the platform. When getting on/off, lower the platform to the lowest position, face the machine, and always use three-point support (for example, two arms and one leg, or one arm and two legs).
- After getting on the platform, attach the entry chain or close the entry gate without fail. Do not operate the machine with the gate open.
- Do not operate the machine roughly. The operator may be thrown from the platform.
- Keep the platform neat and tidy always. To avoid slips, clear the water, oil, snow, ice off the platform.
- Do not step on any places other than the platform.

### 5. Collision Hazards

#### **⚠ WARNING**

- Make sure that no person or obstacle is around the machine. Be aware of blind spots when traveling or operating. If your view is obstructed, have another person assist you.

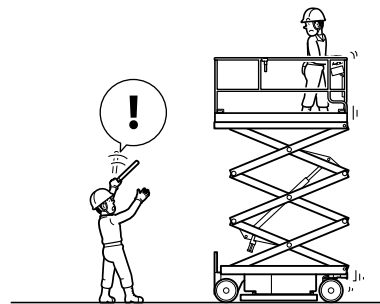

Fig. 1-9

M081U503

- When raising or lowering the platform, check that there is enough space above, below, and on all sides of the machine.
- Do not hit structures etc. with the machine while traveling.

- Once the platform is raised, do not allow people or things under the platform.



Fig. 1-10

- Do not lower the platform unless the area below is clear of persons and obstacles.
- When you go under the platform for checks, you must remove any load from the platform, and support the scissor arm with the included safety prop so that the scissor arm does not come down. (Refer to Chapter 3 for details.)
- Stow the safety prop (Fig. 1-11, P) in its stowage position (Fig. 1-11, S) when it is not used.

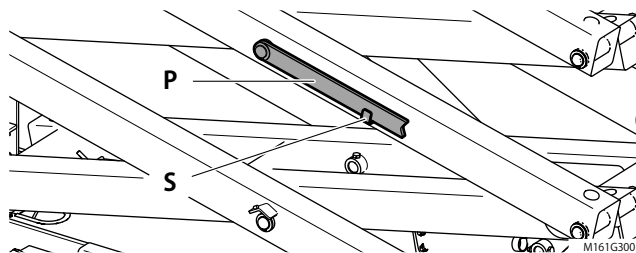

Fig. 1-11

- Take care that your hands on the guardrails are not caught in other obstacles.
- Do not drop things from the platform. There is a hazard that falling objects will hit cars, or people that are passing by.



Fig. 1-12

- The machine is not allowed to travel on public highways.

## 6. Damaged Machine Hazards

### **⚠️ WARNING**

- Do not use a damaged or malfunctioning machine. Have it checked and repaired immediately.
- If you sense any abnormalities in the machine during operation, immediately stop operation and check the machine.
- When operators change a work shift, perform the pre-operation checks at every change. It is the operator's responsibility to perform a pre-operation check.
- Perform the pre-operation checks on a firm level surface, with the platform lowered, and the extension deck retracted.
- If the pre-operation checks reveal any abnormalities, put an "Out of Order" sign on the machine, and stop using the machine. Report the problem to your supervisor.
- Perform all maintenance described in this manual and in the designated service manual for the machine.
- Make sure all decals are in place and not damaged. Any decal missing or damaged should be treated as a machine malfunction.

## 7. Fire Hazards

### **⚠️ WARNING**

- When handling flammables (fuel, oil, etc.), be aware of anything that can cause fire.
- Have a first-aid kit and a fire extinguisher ready in case of an accident or fire.
- If the machine is to be used in a location where flammable gas is produced, only use the machine after sufficient ventilation.

## 8. Battery Safety

### Tip Over Hazard

#### **! DANGER**

- Do not use a battery that weighs less than the specified battery.  
(See Section 2 of Chapter 1 for details.)

### Burn Hazards

#### **! WARNING**

- The battery fluid contains corrosive acid. When dealing with the battery, always wear appropriate protective clothing and equipment to protect your hands, eyes, face and body, and avoid contacting battery fluid.
- If battery fluid gets on the skin or on clothing, wash it away immediately with cold water. If it gets into the eye, wash immediately with cold water, and seek medical treatment immediately.

### Explosion Hazard

#### **! WARNING**

- The battery produces flammable hydrogen gas, and there is a possibility of explosion. Never allow anything that can cause fire to be close to the battery. Charge the battery only under good ventilation.
- If the battery fluid is frozen, slowly warm the battery before charging it. Do not charge the batteries if their temperatures are below 3 °C as the battery fluid may have frozen.
- If equipped with optional AGM batteries, be sure to charge them only in combination with the battery charger built in the machine. Otherwise, leakage of electrolyte, heating, or explosion may result.

## 9. Personal Safety

### Fall Hazards

#### **! DANGER**

- When working, wear appropriate protective clothing and equipment. All persons in the platform must comply with employer, work area, and local and national safety regulations regarding the use of a personal protective equipment. All personal protective equipment must comply with applicable regulations, and must be inspected and used in accordance with the manufacturer's instructions.
- All personal fall protective equipment must be attached to only the authorized lanyard anchorage points provided in the platform.



### Exposure Hazards

#### **! WARNING**

- Wear personal protective equipment such as gloves, work shoes, eye and hearing protection as required by the task at hand.
- Never wear jewelry, unbuttoned cuffs, ties or loose-fitting clothing when you are working near moving / rotating parts such as the cooling fan or flywheel.
- Always tie back long hair when you are working near moving / rotating parts such as a cooling fan or flywheel.
- Never operate the machine while wearing a headset to listen to music or radio because it will be difficult to hear the alert signals.

### Alcohol and Drug Hazards

#### **! WARNING**

- Never operate the machine while you are under the influence of alcohol or drugs.
- Never operate the machine when you are feeling ill.

# Chapter 2

## Decals

### 1. Symbol and Pictorials Definitions





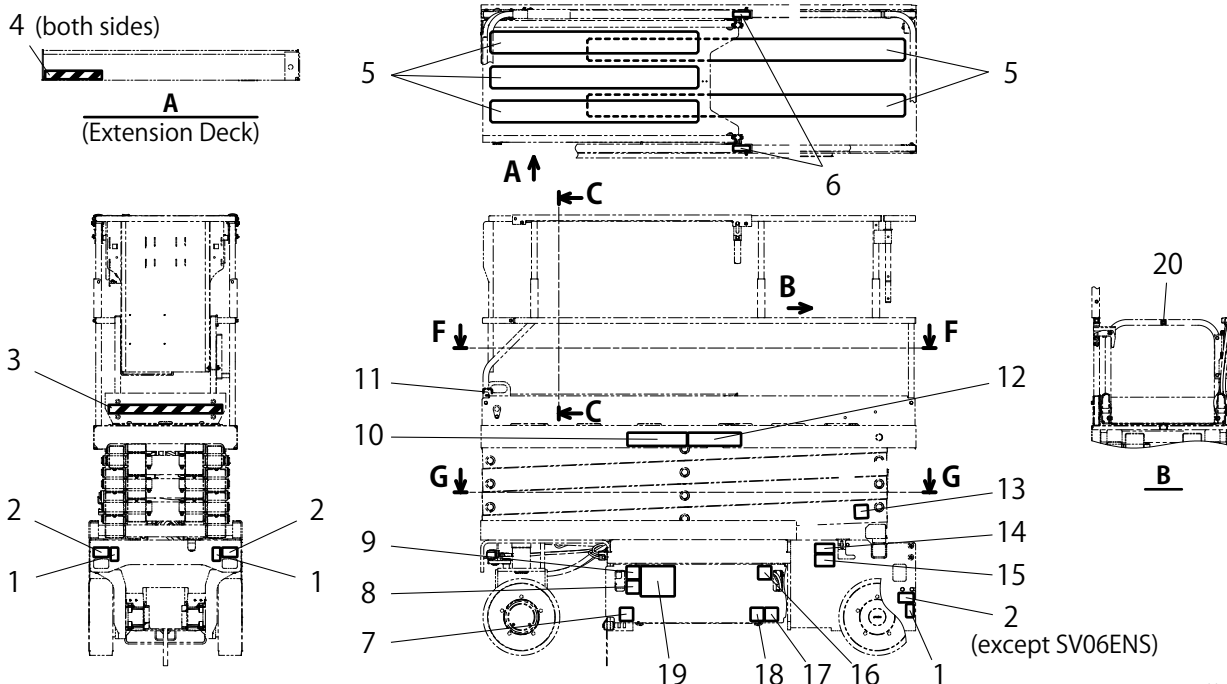

 Read operation manual.	 Crush Hazard	 Crush Hazard	 Falling Hazard	 Maintain required clearance.	 Do not wash by high pressure.
 Do not step. Keep off.	 No smoking. No open flame.	 Do not use the machine on/near soft or uneven surfaces.	 Do not travel near drop offs, holes or other hazards.	 Do not travel onto a slope with platform raised; do not raise platform on/near a slope.	 Avoid overhead obstructions.
 Keep away. Do not touch.	 No wind.	 Emergency Lowering Lever	 Safety Prop	 Maximum Wind Speed	 Maximum Manual Force
 Main Platform Capacity	 Extension Deck Capacity	 Loads (personnel and tools)	 Maximum Slope Rating; Tilt Warning	 Maximum Side Slope Rating	 Maximum Wheel Load
 Tie-down Point	 Lift Point	 Forklift Point	 Forklift Point, Left End	 Forklift Point, Right End	 Lanyard Anchorage Point
 Hydraulic Oil	 Platform Overload	 System Failure	 Battery	 ON and OFF	 Pre-Operation Check
 Horn	 Enable Switch	 Steer: Left / Right	 Travel: Forward / Backward	 Lift: Raise / Lower	 Capacity Mode Selection
 Indoor / Outdoor Mode Selection	 Lower Controls / Off / Upper Controls Selection				

## 2. Safety Signs and Locations

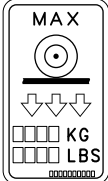
### Front View, Left Side View & Top View

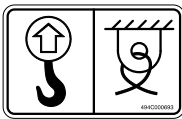







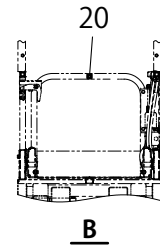
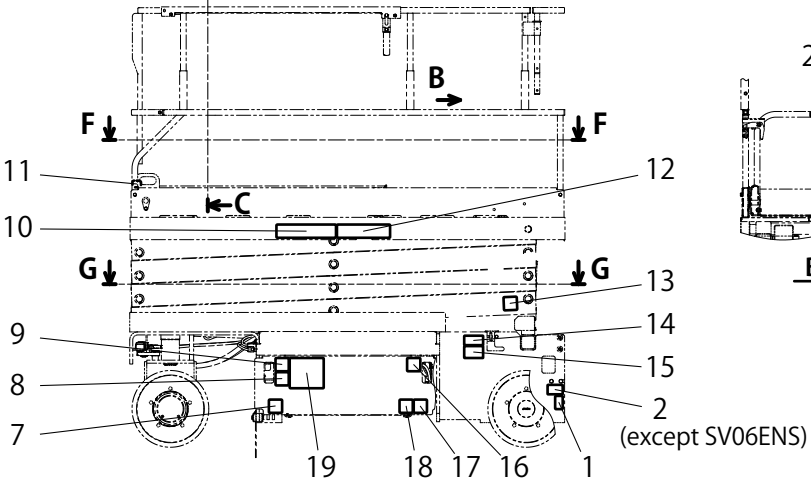
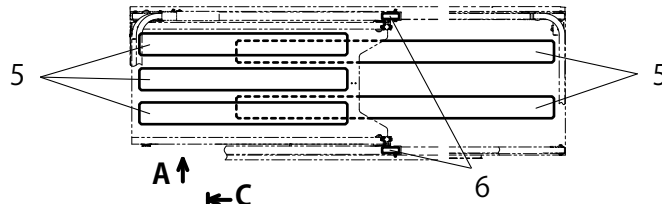
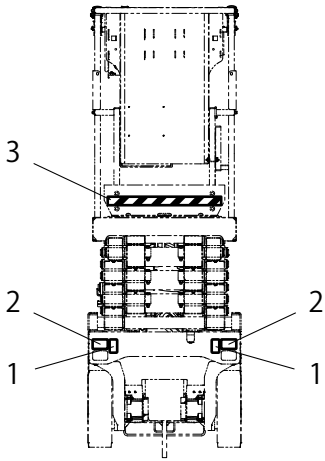
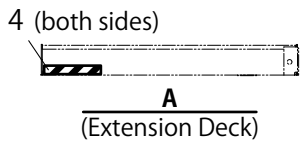

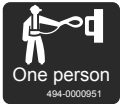

M1665124

No.		No.	
1	5Y6-04144-00 (SV06ENS) 5Y6-07514-00 (SV06ENL, SV08ENL) 5Y6-07877-00 (SV08EWL, SV10EWL)  (Wheel load varies with each model.)	7	494-0000932 
2	494-C000693 	8	491-C000804 
3	(Caution Stripe) 494-C000703 (SV06ENS, SV06ENL, SV08ENL) 494-C000728 (SV08EWL, SV10EWL)	9	491-C000801 
4	(Caution Stripe) 494-C000704	10 (Model code/commercial name) 5Y6-07589-00 (SV06ENS) 5Y6-07594-00 (SV06ENL) 5Y6-07600-00 (SV08ENL) 5Y6-07596-00 (SV08EWL) 5Y6-07601-00 (SV10EWL)  (Decal varies with each model, may not be as shown.)	
5	(Non-Slip Tape)		
6	491-C000812 		

Front View, Left Side View & Top View (Continued)



M166S124

No.		No	
11	494-0000951 	17	494-0000933 
12	182-01003 	18	491-C000802 
13	491-C000800 	19	5Y6-07510-00 
14	5Y6-C5368-00 		
15	5Y6-08003-00 		
16	491-C000809 	20	491-C000807 



Right Side View

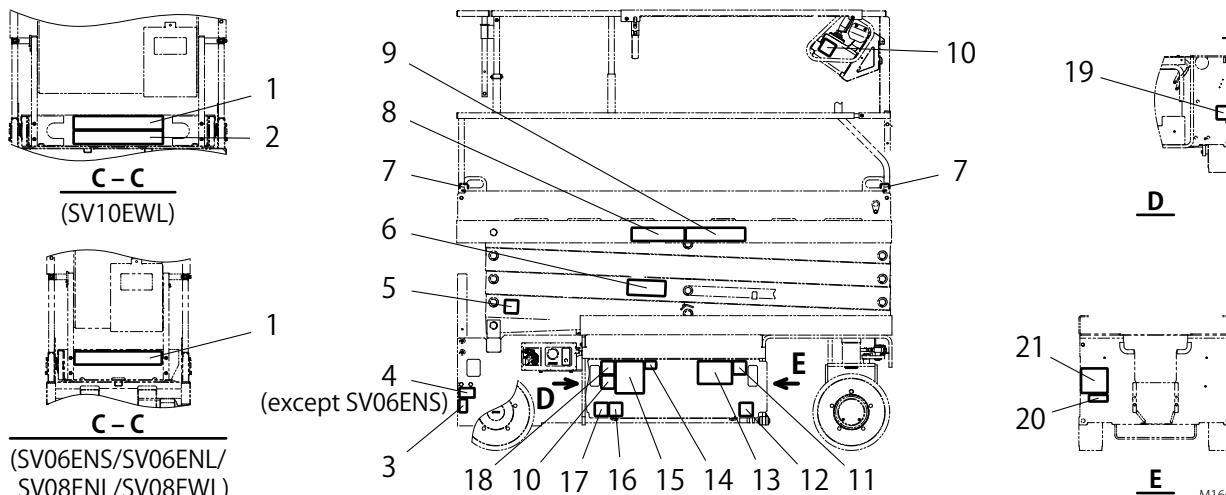







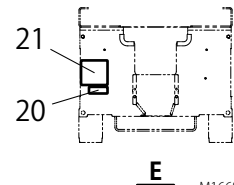
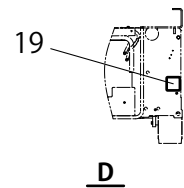
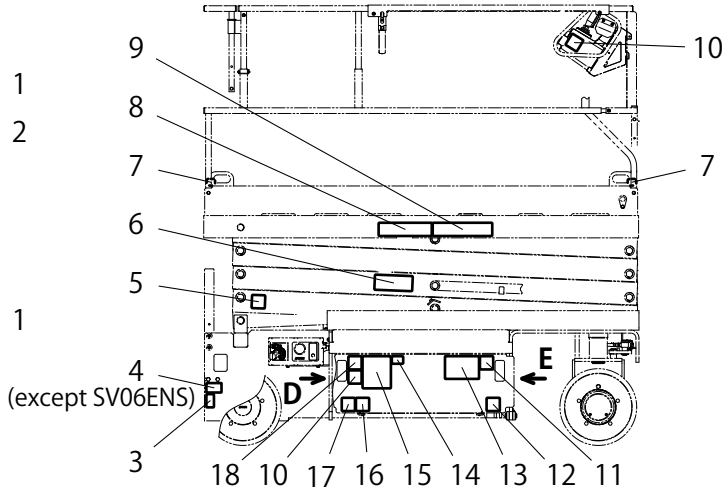
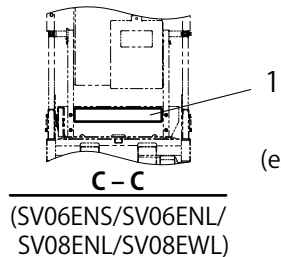
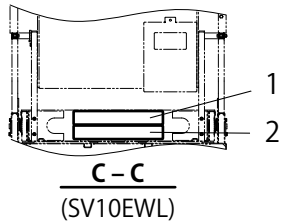

M1665224

No.		No.	
1	<p>5Y6-07874-00 (SV06ENS)</p> <p>5Y6-07885-00 (SV06ENL)</p> <p>5Y6-07876-00 (SV08ENL)</p> <p>5Y6-07928-00 (SV08EWL)</p> <p>5Y6-07879-00 (SV10EWL)</p>	5	<p>491-C000800</p>
		6	<p>5Y6-07505-00</p>
		7	<p>494-0000951</p>
2	<p>5Y6-07878-00 (SV10EWL)</p>	8	
3	<p>5Y6-04144-00 (SV06ENS) 5Y6-07514-00 (SV06ENL, SV08ENL) 5Y6-07877-00 (SV08EWL, SV10EWL)</p> <p>(Wheel load varies with each model.)</p>	9	<p>(Model code/commercial name) 5Y6-07589-00 (SV06ENS) 5Y6-07594-00 (SV06ENL) 5Y6-07600-00 (SV08ENL) 5Y6-07596-00 (SV08EWL) 5Y6-07601-00 (SV10EWL)</p> <p>(Decal varies with each model, may not be as shown.)</p>
4	<p>494-C000693</p>	10	<p>491-C000804</p>

Right Side View (Continued)

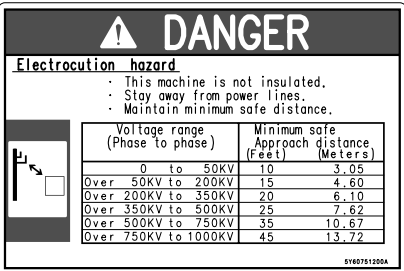

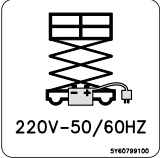
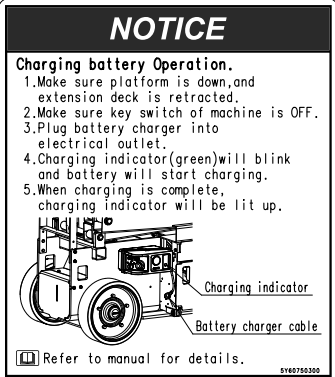

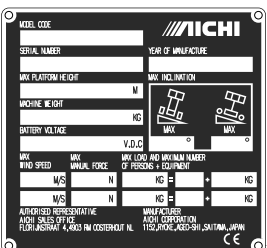

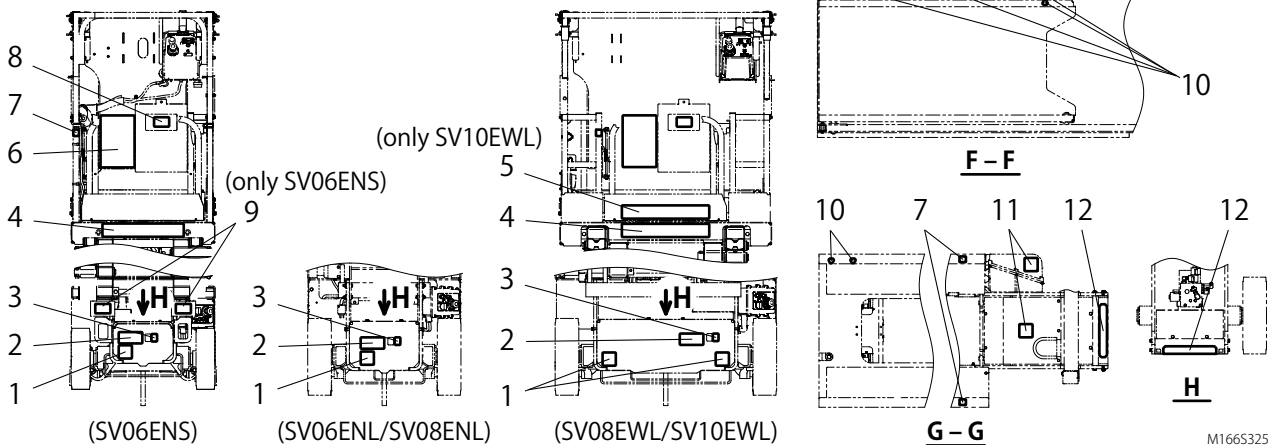

M1665224

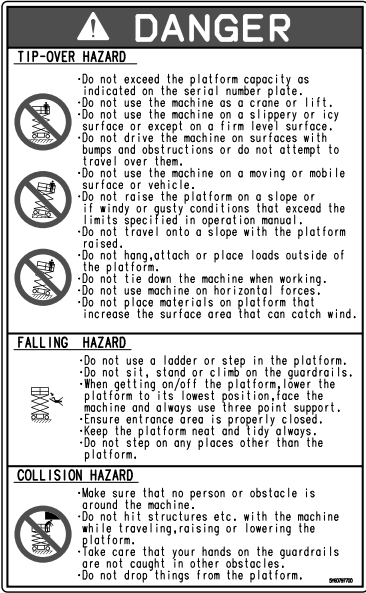
No.		No.	
11	491-C000809 	16	491-C000802 
12	494-0000933 	17	494-0000932 
13	5Y6-07512-00 	18	491-C000801 
14	494-C000699 	19	5Y6-07991-00 
15	5Y6-07503-00 	20	494-0000903 
		21	(Serial number plate) 493-0000064 

Back View & Each Part

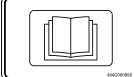
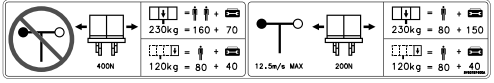
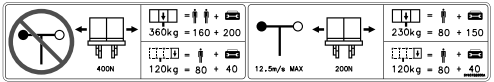
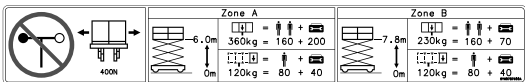
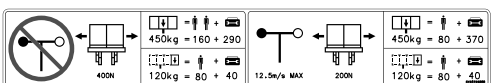
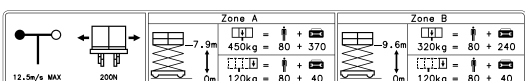
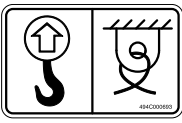
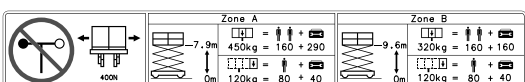

No.		No.	
1	494-C000690 	6	5Y6-07977-00 
2	491-C000803 	7	491-0000965 
3	5Y6-07585-00 	8	494-C000692 
4	5Y6-07874-00 (SV06ENS)  5Y6-07885-00 (SV06ENL)  5Y6-07876-00 (SV08ENL)  5Y6-07928-00 (SV08EWL)  5Y6-07879-00 (SV10EWL) 	9	494-C000693 
5	5Y6-07878-00 (SV10EWL) 	10	(Arrow, red)
		11	491-C000804 
		12	(Non-slip tape)

### Upper Controls & Lower Controls

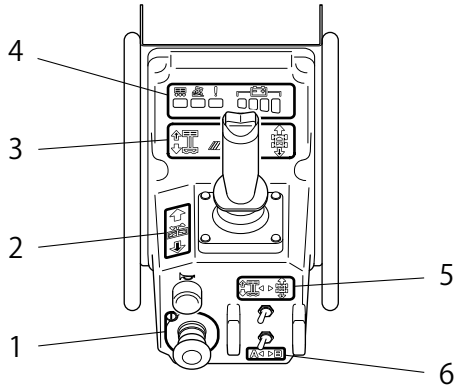



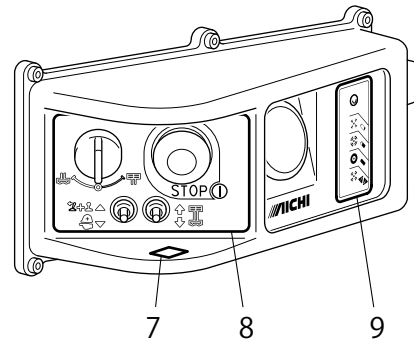



**Upper Controls**

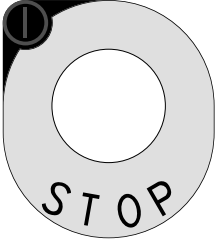
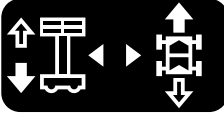

**Lower Controls**

M1665421

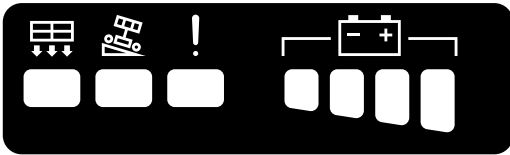
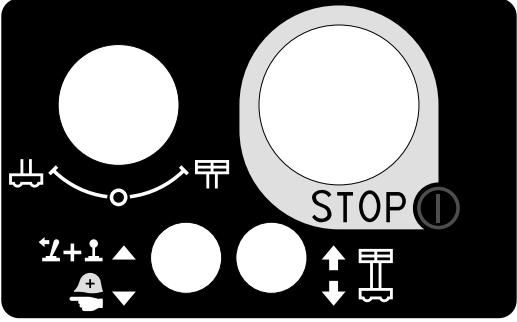
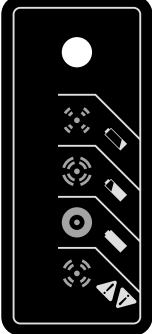
No.		No.	
1	5Y6-07306-00 	5	5Y6-07472-00 
2	5Y6-07473-00 	6	5Y6-07474-00 (SV08ENL, SV10EWL)  5Y6-07867-00 (SV06ENL) 
3	5Y6-07579-00 	7	491-C000807 
4	5Y6-07611-00 	8	5Y6-07305-00 
9	5Y6-07312-00 		

# Chapter 3

## Safety Systems & Devices

### **⚠️ WARNING**

It is strictly forbidden to make modifications to the machine without obtaining AICHI's written approval. Do not disable or alter the machine's components that have an effect on safety and stability in any way.

Failure to heed warnings could result in decreasing safety, stability, and strength of the machine, or other hazards leading to death or serious injury.

### 1. List of Safety Systems

#### (1) Emergency Stop Device

The machine is equipped with readily identifiable emergency stop buttons, located at both the upper and lower controls. It stops all of the movements of the machine when this button is pressed.

#### (2) Emergency Lowering

This is an emergency lowering device for when the platform has been raised, and cannot be lowered because of problems with the power source.

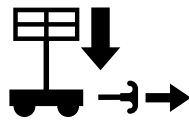

The emergency lowering handle (Fig. 3-1, A) is located at the rear side of the machine. The handle is connected, by a cable, to the holding valve on the lift cylinder. Pulling the handle opens the valve spool, lowering the platform.

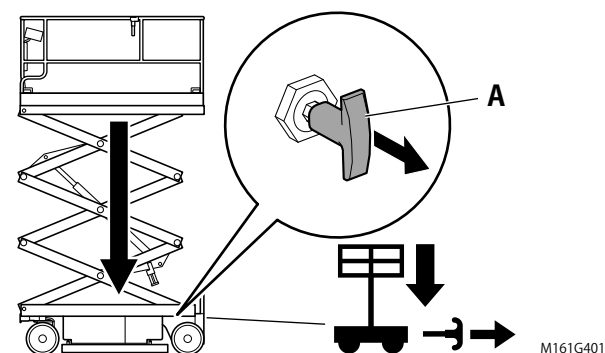

Fig. 3-1

#### (3) Guardrail System

There are guardrails on all sides of the platform to help prevent persons in the platform from falling off the platform. The entry gate is part of the guardrail system and must be securely fastened after entering the platform.

#### (4) Lanyard Anchorage Point

If the personal fall protective equipment is used, attach to only the authorized lanyard anchorage points provided in the platform.

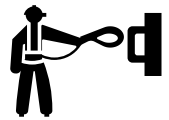

#### (5) Pothole Protector

When the platform has been raised, the pothole protectors come down automatically. It provides pothole protection for traveling with the platform raised.

### **NOTICE**

- If the pothole protectors are in contact with the ground, immediately lower the platform fully and stop using the machine. Perform the workplace check again and judge whether to allow the use of the machine.
- If traveling on a place where the use of the machine is not allowed (e.g., a floor there is an obstacle), the pothole protectors could get stuck in the obstacle, consequently making travel impossible. In this case, transport the machine to a firm level surface. Refer to Chapter 10 for transportation.

#### (6) Pothole Protector Interlock

If the pothole protectors are unable to lock in position because an object is caught under it, the machine will not travel and the platform will not be raised.

### (7) Safety Prop

The safety prop is a support pole that prevents the scissor arms from lowering when it is necessary to do maintenance work under the scissor arms or platform.

For information on how to use this equipment, see the Section 2 "Safety Prop".

### (8) Battery Disconnect System

The battery disconnecter (Fig. 3-2, A) located in the left battery box cuts off the battery electrically. When electrical maintenance is performed, always disconnect the battery using the disconnecter.

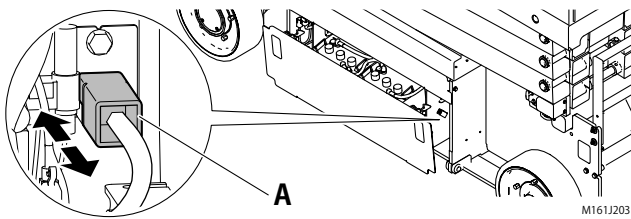

Fig. 3-2

### (9) Platform Lift up Limit System

This system disables the platform lift up function, turns on the tilt light, and sounds the tilt alarm buzzer when the machine is on a slope. When the tilt alarm buzzer sound starts, immediately lower the platform and move to a firm, level surface.

### (10) Enable Switch

The platform lift, travel and steering functions are disabled unless the enable switch is operated.

### (11) Enable Switch Cancel System

This system cancels the enable switch if any of the platform lift, travel and steering functions are not operated for more than 20 seconds after operating the enable switch.

The system also cancels the functions if the enable switch is not operated for more than 20 seconds after operating any of the platform lift, travel and steering functions.

At this time, the system failure light turns on.

In this case, release all controls and the system failure light will turn off. And then operate again to enable the functions.

### (12) Overload Sensing System

This system disables all of the functions, flashes the overload warning light, and sounds the overload warning buzzer when the platform has been overloaded. When the overload warning buzzer sound starts, immediately reduce the load on the platform.

## NOTICE

**Make sure all platform loads are evenly distributed. The overload sensing system may activate though the platform load does not reach the platform load capacity if loads are not evenly distributed or are inclined to one side.**

**The system may also activate though the load does not reach the capacity when operating the machine in low temperature environments.**

### (13) Platform Lift Down Limit System

The platform automatically stops lowering at a specified height before it lowers fully.

Release all switches. Make certain the area under the platform is clear of all obstructions and personnel, then continue to lower the platform. (The platform does not lower for 3 seconds after releasing the switches.)

## 2. Safety Prop

### **⚠️ WARNING**

When you go under the platform for checks, you must remove any load from the platform, and support the scissor arm with the included safety prop so that the scissor arm does not come down.

### 2-1 How to Use Safety Prop

#### Step 1

Remove all materials from the platform.

#### Step 2

Raise the platform until there is enough clearance to rotate down the safety prop.

#### Step 3

Push in the emergency stop button to "OFF" and stop all functions.

#### Step 4

Set up the safety prop as follows.

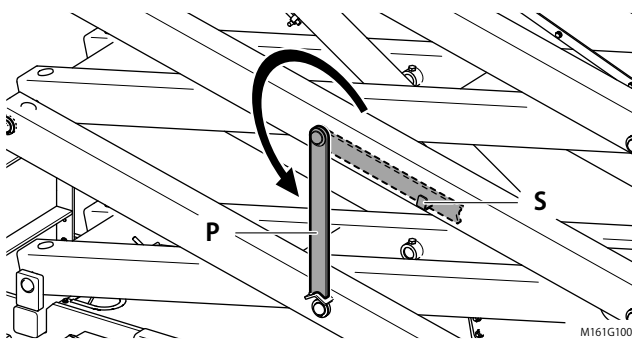

Fig. 3-3

- (1) Lift the safety prop (Fig. 3-3, P) from its stowage position (Fig. 3-3, S) located on the right side of the machine.
- (2) Rotate the safety prop down to a vertical position.

#### Step 5

Pull out the emergency stop button to "ON."

### **⚠️ WARNING**

Keep a safe distance from scissor arms when lowering the platform.

#### Step 6

Lower the platform carefully until the safety prop rests securely on the safety prop rest (Fig. 3-4, R).

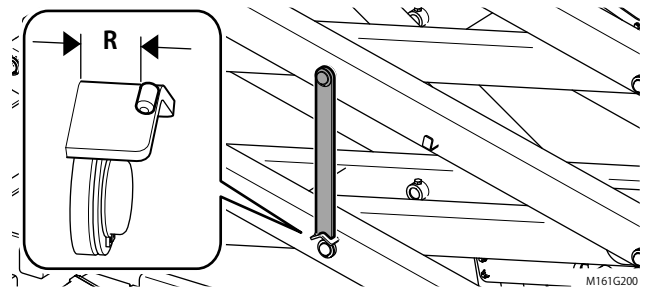

Fig. 3-4

#### Step 7

Push in the emergency stop button to "OFF" and stop all functions.

### 2-2 Stowing Safety Prop

### **NOTICE**

Stow the safety prop in its stowage position (Fig. 3-3, S) when it is not used.

#### Step 1

Pull out the emergency stop button to "ON."

#### Step 2

Raise the platform until there is enough clearance to rotate up the safety prop.

#### Step 3

Push in the emergency stop button to "OFF" and stop all functions.

#### Step 4

Stow the safety prop in its stowage position.

# Chapter 4

## Part Names and Functions

### 1. Part Names of the Machine

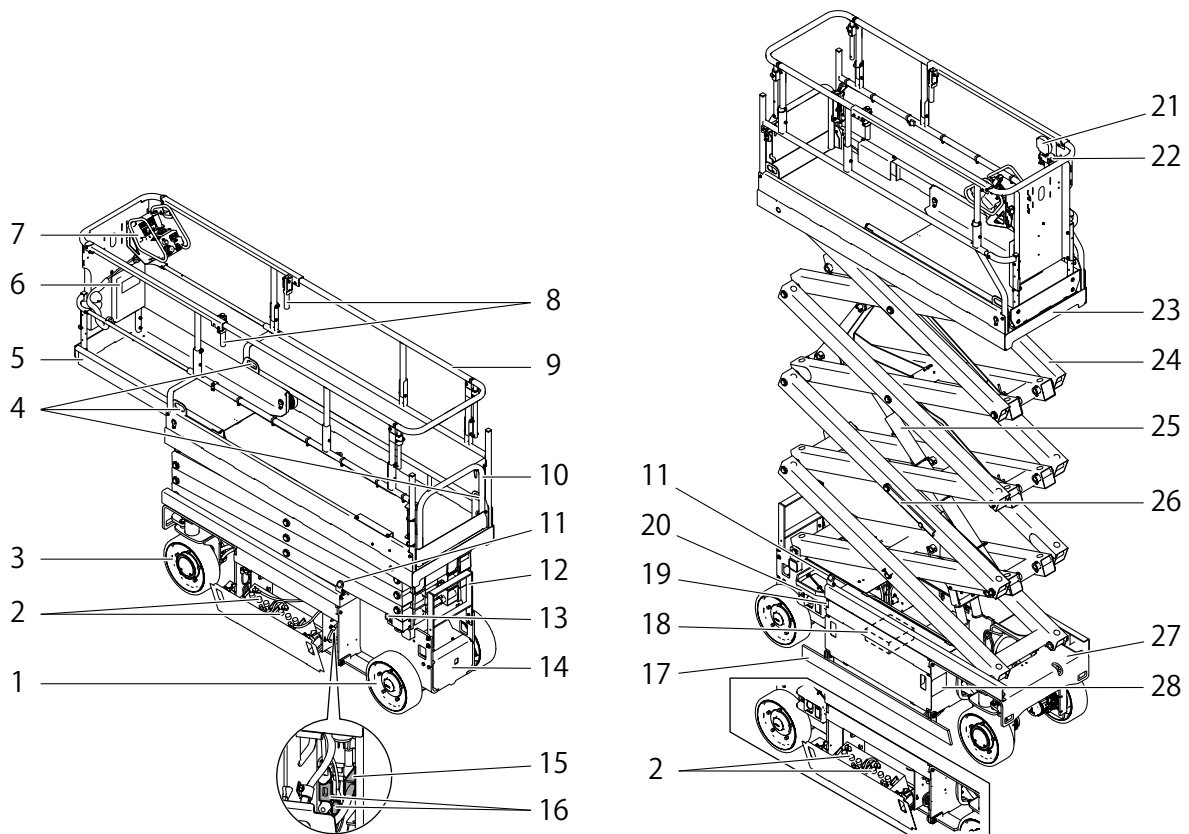

Fig. 4-1

M16XR12-1

1. Rear Wheels
2. Batteries
3. Front Wheels (Steer/Drive Wheels)
4. Lanyard Anchorage Points
5. Extension Deck
6. Manual Holder
7. Upper Controls
8. Handles
9. Guardrails
10. Entry Gate (Door)
11. Flash Beacons
12. Step
13. Emergency Lowering Lever
14. Hydraulic Oil Tank & Power Unit
15. Battery Disconnect
16. Fuse
17. Pothole Protectors
18. Battery Charger
19. Battery Charger Cable
20. Lower Controls
21. Working Light (Option)
22. Working Light Switch (Option)
23. Platform
24. Scissor Arms
25. Lift Cylinder
26. Safety Prop
27. Chassis
28. Serial Number Plate

### NOTICE

Above figure is SV08ENL with options.  
Other models are also similar.



## 2. Upper Controls

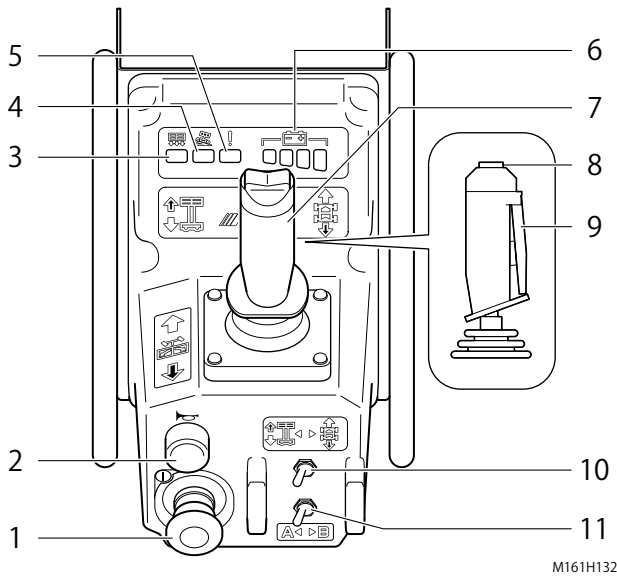

Fig. 4-2

M161H132

### 1. Emergency Stop Button

Push in the emergency stop button to its "OFF" position to stop all functions. Pull out the emergency stop button to its "ON" position to operate the machine.

### 2. Horn Button

Push the horn button and the alarm horn will sound. Release the horn button and the alarm horn will stop.



Before moving the machine, sound the horn to warn the personnel around the machine.

### 3. Overload Warning Light

When the platform has been overloaded, this light flashes, an alarm buzzer sounds and all of the functions are disabled.

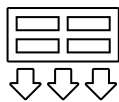

## NOTICE

Make sure all platform loads are evenly distributed. The overload sensing system may activate though the platform load does not reach the platform load capacity if loads are not evenly distributed or are inclined to one side.

The system may also activate though the load does not reach the capacity when operating the machine in low temperature environments.

### 4. Tilt Light

When the machine is on a slope, this light turns on.

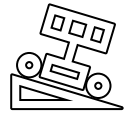

### 5. System Failure Light

This light flashes, in the event of a computer control system failure.



Table 4-1 System Failure Indications

LED status	Causes	Countermeasures
Stays On	Enable switch cancel system is activated.	Release all controls and the system failure light will turn off. And then operate the controls again.
Flashes twice	Either one of the front (drive) wheels is spinning.	Release all controls or Power cycle the machine and the system failure light will turn off. And then operate the controls again.
	Travel motor is faulty.	Stop using the machine.
Flashes 7 times	Pothole protectors are stuck and do not come down.	Check the pothole protectors for stuck.
Flashes other than listed above	The machine is faulty.	Stop using the machine.

## NOTICE

- When this light turns on, operations of the machine are disabled. In that case, release all controls and then operate the controls again.
- If this light flashes, check the Multi-function indicator on the lower controls for diagnosis.
- This light also flashes when the key switch is turned on or the emergency stop button is pulled out. However, this does not indicate a system failure.

6. Battery Level Indicator

When the key switch on the lower controls is turned to "UPPER CONTROLS", this indicator turns on and displays the battery level.

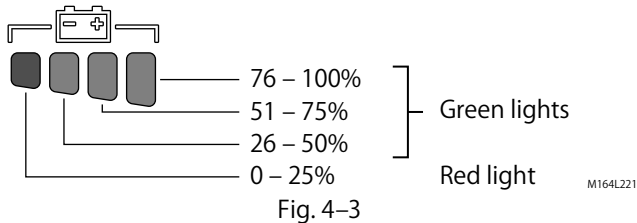
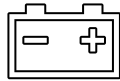

**NOTICE**

- When the battery level is close to 0%, the "0 – 25%" red light will flash.
- When only red light is lit or flashing, immediately recharge the battery of the machine.
- If the indicator lights are repeatedly flashed in sequence, contact AICHI or an AICHI dealer for inspection.



7. Lift/Travel Joystick Controller with Steering Switch

- While the lift/travel select switch is turned to "LIFT", push this joystick controller to lower the platform, pull this joystick controller to lift up the platform.
- While the lift/travel select switch is turned to "TRAVEL", push this joystick controller to travel forward, pull this joystick controller to travel backward.



8. Steering Switch

Press the steering switch (thumb-operated rocker switch on top of joystick) to the left or right and the machine will steer to the left or right. This operation is possible even when traveling. Even when this switch is returned to neutral, the steering wheels will not return to neutral.

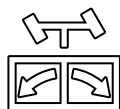

9. Enable switch

Press this switch with the joystick controller in the neutral position, to operate the machine on the platform.

**NOTICE**

- The enable switch must be pressed before operating the platform lift, travel and steering functions. Otherwise, the function operated will not be enabled.
- The enable switch is canceled if any of the platform lift, travel and steering functions are not operated for more than 20 seconds after pressing the enable switch. In that case, release all controls and then operate the controls again.

10. Lift/Travel Select Switch

- Select the "LIFT" position for lifting up/lowering the platform.
- Select the "TRAVEL" position for traveling.

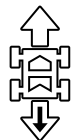
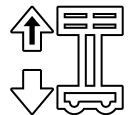

11. Capacity Select Switch

(For SV06ENL)

Select either indoor or outdoor capacity zone using this switch.



Table 4-2 For SV06ENL

Zone	Platform Capacity	Max. Persons
Indoor	360 kg or less	2
Outdoor	230 kg or less	1

(For SV08ENL, SV10EWL)

Select allowable capacity zone using this switch.



Table 4-3 For SV08ENL

Zone	Platform Height	Platform Capacity
A	0 – 6.00 m	360 kg or less
B	0 – 7.77 m	230 kg or less

Table 4-4 For SV10EWL

Zone	Platform Height	Platform Capacity
A	0 – 7.90 m	450 kg or less
B	0 – 9.68 m	320 kg or less

### 3. Lower Controls

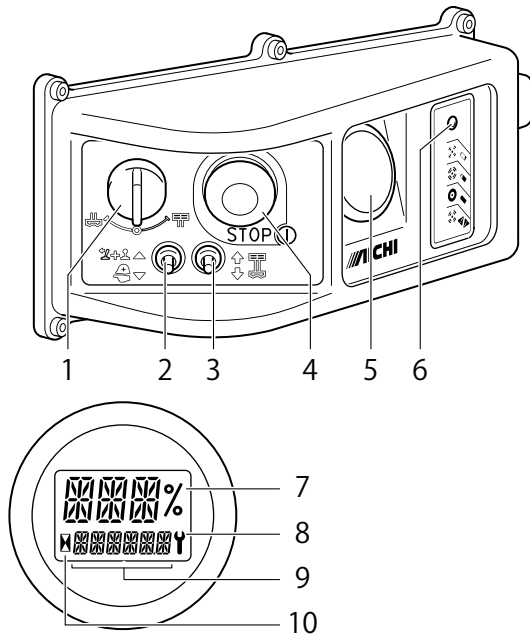

**Details of 5**

Fig. 4-4

M161H233

1. Key Switch for Upper Control / Off / Lower Control Selection

- Turn the key switch counter-clockwise and the upper controls will operate.
- Turn the key switch to center position and the machine will be off.

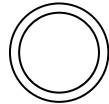
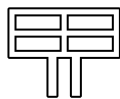

- Turn the key switch to the right and the lower controls will operate.

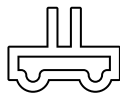

2. Enable Switch / Pre-Operation Check Switch

- Hold this switch up, to operate the machine on the ground.
- Follow the instruction and hold this switch down when the pre-operation check is performed.



3. Lift Switch

Operate this switch up and the platform will lift up.  
Operate this switch down and the platform will lower.

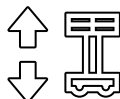

4. Emergency Stop Button

Push in the emergency stop button to its "OFF" position to stop all functions. Pull out the emergency stop button to its "ON" position to operate the machine.

5. Multi-function Indicator

When the key switch on the lower controls is turned to either "UPPER CONTROLS" or "LOWER CONTROLS", this indicator turns on and the battery level is shown on the digital display.

6. Battery Charger Indicator Light

This light displays the battery charger status as shown in a table below:

**Table 4-5 Battery Charger Indications**

LED Color	Indications (following "Power-On Self Test")
Green	<ul style="list-style-type: none"> <li>Stays On: Charging complete. Charger in Maintenance Mode.</li> <li>Flashing Long: &gt;80% Charge.</li> <li>Flashing Short: &lt;80% Charge.</li> </ul> <p><i>When battery is not connected:</i> Algorithm Number displays. (Factory setting: 3 times flashing)</p>
Yellow	Flashing: Reduced Power Mode: Low AC Voltage or High internal charger temperature.
Red	Flashing: Charger error. Reset charger power and refer to "Battery Charger Fault Codes."

## NOTICE

**If a fault occurs, count the number of red flashes between pauses and refer to Section 1 of Chapter 12 for "Battery Charger Fault Codes".**

7. Digital Display

- Under normal conditions, the battery level is shown on the digital display.
- When a problem occurs, a diagnostic code such as "LMT" or "ERR" will appear on the digital display. Then, three digit number related to the diagnostic code will appear on the digital display. When more than one set of diagnostic code and number exists, each set will appear on the digital display for 3 seconds before changing on to next set. After the last set appears, the battery level will appear and then the display will return back to the first set.

## NOTICE

**For the diagnostic codes and numbers and their descriptions, refer to Section 2 of Chapter 12 for "Diagnostic Codes Chart".**

8. Wrench Icon

When a problem occurs, the wrench icon will display on the multi-function Indicator.



9. Hour Meter

The hour meter works only when the machine is in motion.

10. Hour Meter Icon

When the hour meter running, the hour meter icon displays and flashes on the multi-function display.



## Chapter 5

# Workplace Check

### **WARNING**

**Do not move the machine to the workplace until the workplace check is performed.**

- Make sure to check the workplace before starting operation. Make sure there is none of the following hazards:
  - Near electric power lines and apparatus
  - Drop-offs or holes, including those concealed by water, ice, mud, etc.
  - Slope(s)
  - Slippery or icy surfaces
  - Bumps and floor obstructions and electrical conductors
  - Debris
  - Curbs
  - Overhead obstructions
  - Hazardous locations and atmospheres
  - Inadequate surface support to withstand all load forces imposed by the machine in all operating configurations
  - Wind and weather conditions
  - Presence of unauthorized persons
  - Other possible unsafe conditions
- Remove the hazards, if any, after the workplace check. If it is not possible to remove them, do not move the machine to the workplace.
- The machine can be used only on level surfaces which are firm and for which all 4 wheels can maintain contact evenly with the ground.
- During work, always pay attention to surroundings and make sure there is no hazard.
- Make sure to check for ambient temperature. The machine is designed to operate in nominal ambient temperature of -20°C to +40°C.

# Chapter 6

## Pre-operation Check

### **WARNING**

- Do not operate the machine before performing pre-operation checks described in this manual.
- Perform the pre-operation checks on a firm, level surface. Begin the checks with the platform lowered, and the extension deck retracted.
- If the pre-operation checks reveal any abnormalities, immediately put an “Out of Order” sign on the machine, and stop using the machine. The use of the machine not repaired can cause a serious accident. After repairs are completed, perform the pre-operation checks again from the beginning.
- If there is damage, such as cracks, on the welds of the platform guardrails, or on the guardrail pipes, replace the guardrails immediately.
- If there is damage, such as cracks or bends, on the pothole protectors, replace the pothole protectors immediately.
- Damage and stains to the decals will obstruct correct handling. Immediately remove the stain, or replace the decals.
- Make sure to perform the checks with no load on the platform.

### **NOTICE**

- The motion alarm buzzer sounds when the machine is in motion to warn to the people nearby.
- Make a copy of the daily inspection check sheet (at the end of this manual). Make a check in the appropriate box on the sheet while performing the pre-operation checks.

## 1. Visual Check

### *Step 1*

Circle the machine once and check visually that there are no oil leaks, and no damage to the machine.

### *Step 2*

Check for cracks, deformation, or damage in the scissors, platform, and other parts.

### *Step 3*

Check for wetness, dirt, or damage in AC outlet, inlet receptacle, and each switch. Check for damage in wire harnesses.

### *Step 4*

Check that all the covers are closed securely and all the guardrails are attached properly. Check for loose, damaged, or missing bolts.

### *Step 5*

Check that all decals are in place, legible, and not damaged. Replace any missing or damaged decals. Use mild soap and water to clean decals. Refer to Chapter 2 for decals and their locations.

### *Step 6*

Check the hydraulic oil level when the platform is completely lowered. Refer to Section 2-1 of Chapter 7 for details.

### *Step 7*

Check for battery fluid leaks, and check that there is sufficient battery fluid. Refer to Section 2-2 of Chapter 7 for details.

### *Step 8*

Check all tires for damage, chippings of block, and uneven wear. Check all wheels are properly secured and no missing bolts.

### Step 9

Check that the antistatic strap is installed and touching the ground.

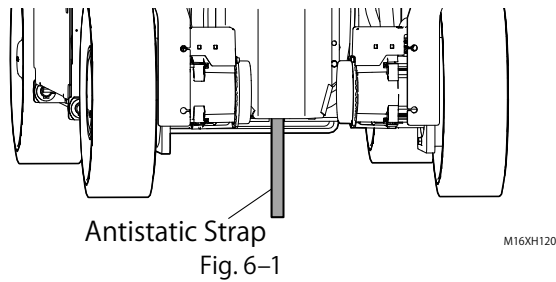

### Step 13

Check the battery level indicator on the upper controls and make sure that the one or more green lights are lit.

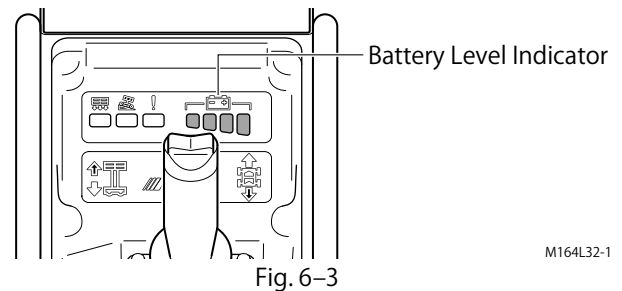

## 2. Function Check

### 2-1 Preparations for Function Check

#### Step 10

Put the machine in the following state:

- Put the machine on a firm level surface.
- Lower the platform completely.
- Retract the extension deck.
- Operate the machine from the lower controls.
- Unload the platform.

#### Step 11

After charging the batteries, remove the charging plug from the power outlet, and store in the designated place.

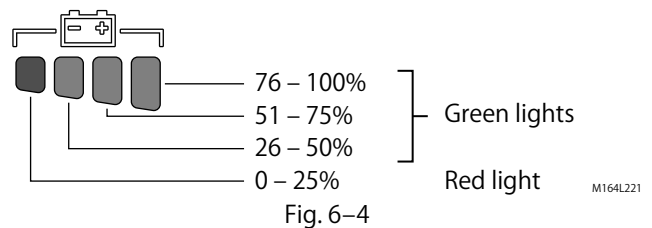

## NOTICE

If only red light is lit or flashing, charge the batteries and then perform the pre-operation checks.



### 2-2 Battery Level Check

#### Step 12

Turn the key switch to "UPPER CONTROLS".

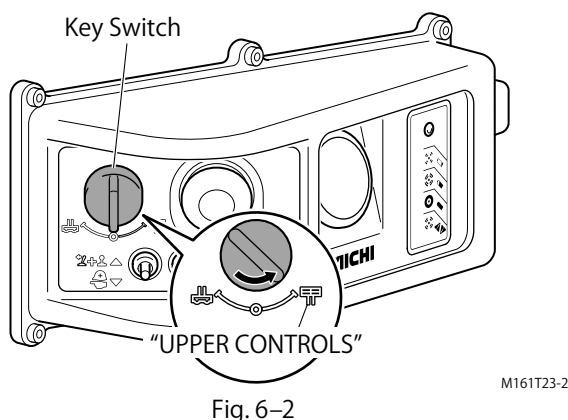

### 2-3 Lower Controls Check

## NOTICE

Hold the enable switch up to operate the machine on the ground except in steps from Step 14 to Step 18.

#### Step 14

Turn the key switch to "LOWER CONTROLS".

#### Step 15

Hold the pre-operation check switch down and hold the lift switch "UP". Make sure that the platform rises and the alarm buzzer sounds.

#### Step 16

Make sure that the wear pad stops between the red arrows on the chassis.

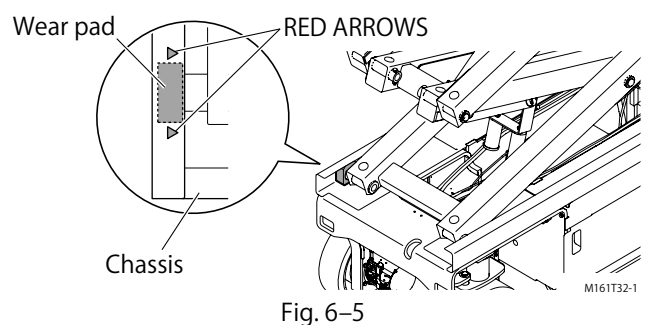

### Step 17

After confirming that the wear pad has stopped between the red arrows, continue holding the pre-operation check switch down and the lift switch "UP" for another 5 seconds.

### Step 18

Confirm that the alarm buzzer stops sounding and then release both the pre-operation check switch and lift switch.

## NOTICE

**If the alarm buzzer does not stop after 5 seconds from stopping the wear pad, the "LIFT UP" function for the platform will be disabled and the error codes "ERR" and "30B" will appear on the digital display in the multi-function indicator.**

### Step 19

- (1) Make sure the pothole protectors are completely down.
- (2) Check for cracks, deformation, or damage in the pothole protectors.
- (3) Push the pothole protectors. Make sure they do not move.

### Step 20

- (1) Raise and lower the platform completely a few times.

Make sure the platform operates smoothly (no strange noises, vibrations, or rattling).

- (2) The platform automatically stops lowering when it is lowered to a height below from ground:

- approx. 1.5 m (SV06ENS/SV06ENL)
- approx. 1.8 m (SV08ENL)
- approx. 2.0 m (SV08EWL/SV10EWL)

Release all switches. Make certain the area under the platform is clear of all obstructions and personnel, then continue to lower the platform. (The platform does not lower for 3 seconds after releasing the switches.)

### Step 21

- (1) Push in the emergency stop button.
- (2) Attempt to raise and lower the platform.  
Make sure that these functions are disabled.
- (3) Pull out the emergency stop button to release the stop state.

## 2-4 Natural Descent Check

### Step 22

Raise the platform to approx. 2.5 m above the ground.

### Step 23

- (1) Leave the machine for 5 minutes.
- (2) Check visually that the platform remains in its position.

### Step 24

Lower the platform completely.

## 2-5 Upper Controls Check

### CAUTION

**When getting on or off the platform, use three-point support (for example, 2 arms and 1 leg, or 1 arm and 2 legs).**

## NOTICE

**Press the enable switch to operate the machine on the platform.**

### Step 25

Turn the key switch to "UP" (UPPER CONTROLS).

### Step 26

Get on the platform and close gate.

If wearing the safety harness, after getting on the platform, immediately attach the lanyard of the safety harness to the specified lanyard anchorage point.

### Step 27

- (1) Turn the lift/travel select switch to "LIFT".
- (2) Raise and lower the platform completely a few times.

Make sure the platform operates smoothly (no strange noises, vibrations, or rattling).

- (3) The platform automatically stops lowering when it is lowered to a height below from ground:

- approx. 1.5 m (SV06ENS/SV06ENL)
- approx. 1.8 m (SV08ENL)
- approx. 2.0 m (SV08EWL/SV10EWL)

Release all switches. Make certain the area under the platform is clear of all obstructions and personnel, then continue to lower the platform. (The platform does not lower for 3 seconds after releasing the switches.)



### Step 28

- (1) Turn the lift/travel select switch to "TRAVEL" (TRAVEL).
- (2) Operate the lift/travel joystick controller slightly and slowly to "BACKWARD" and "FORWARD." Make sure the machine travels backward and forward accordingly.
- (3) Return the lift/travel joystick controller to neutral.  
Make sure the machine stops.

### Step 29

Travel a few feet, and make sure the machine operates smoothly (no strange noises, vibrations, or rattling). Repeat a few times.

### Step 30

Steer and make sure the steering is smooth (no strange noises, vibrations, or rattling).

### Step 31

- (1) Push in the emergency stop button.
- (2) Attempt to drive the machine backward and forward, and to steer left and right.  
Make sure that these operations are disabled.
- (3) Turn the lift/travel select switch to "LIFT" (LIFT).
- (4) Attempt to raise and lower the platform.  
Make sure that these operations are disabled.
- (5) Pull out the emergency stop button to release the stop state.

### Step 32

Push the horn button. Make sure the alarm horn sounds.

## 2-6 Pothole Protector Check

### Step 33

- (1) Lower the platform completely.
- (2) Place a piece of wood 50 mm thick under the pothole protector.

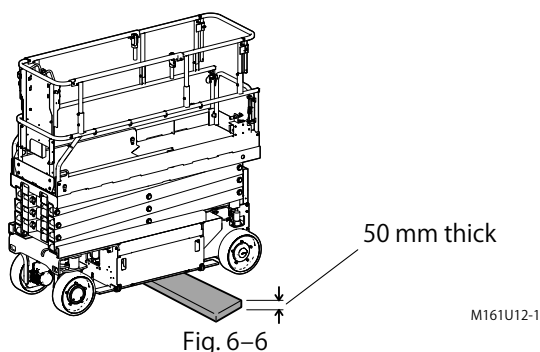

- (3) Raise the platform to approx. 2.5 m above the ground.

- (4) Make sure the pothole protectors are not completely down when it comes in contact with the piece of wood.
- (5) Attempt to raise the platform. Make sure the lift function is disabled.
- (6) Attempt to drive the machine. Make sure the travel function is disabled.
- (7) Lower the platform completely and get off the platform.
- (8) Remove the piece of wood which was placed in (2).

## 2-7 Tilt Warning Check

### Step 34

- (1) Turn the lift/travel select switch to "TRAVEL" (TRAVEL).
- (2) Drive the machine, with the platform lowered, up onto a side slope of 3.5° (6.12 % grade).

#### Guide for 3.5° angle (6.12 % grade)

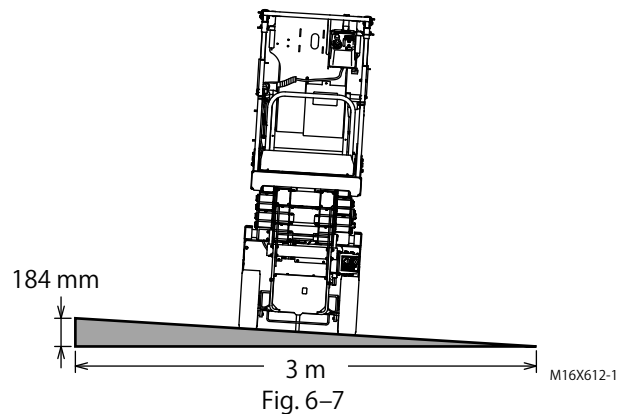

- (3) Make sure that the tilt light goes on.
- (4) Turn the lift/travel select switch to "LIFT" (LIFT).
- (5) Raise the platform to approx. 3 m above the ground.
- (6) Make sure that the platform stops before reaching the desired height and the alarm buzzer sounds.
- (7) Turn the lift/travel select switch to "TRAVEL" (TRAVEL).

### Step 35

- (1) Drive the machine up onto a slope of at least 3.5° (6.12 % grade) within the gradeability.

#### **Guide for 3.5° angle (6.12 % grade)**

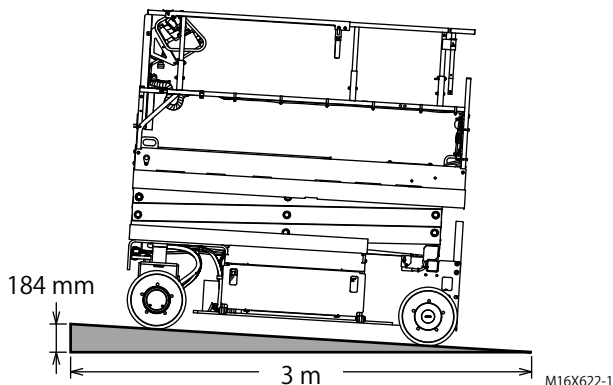

Fig. 6-8

- (2) Make sure that the tilt light goes on.
- (3) Turn the lift/travel select switch to "LIFT" (LIFT).
- (4) Raise the platform to approx. 3 m above the ground.
- (5) Make sure that the platform stops before reaching the desired height and the alarm buzzer sounds.
- (6) Turn the lift/travel select switch to "TRAVEL" (TRAVEL).
- (7) Drive the machine to a firm level surface.

## 2-8 Limited Travel Speed Check

### **CAUTION**

When getting on or off the platform, use three-point support (for example, 2 arms and 1 leg, or 1 arm and 2 legs).

### Step 36

- (1) Wear the safety harness and get on the platform and close gate.  
After getting on the platform, immediately attach the lanyard of the safety harness to the specified lanyard anchorage point.
- (2) Turn the lift/travel select switch to "LIFT" (LIFT).
- (3) Raise the platform to approx. 2.5 m above the ground.
- (4) Turn the lift/travel select switch to "TRAVEL" (TRAVEL).
- (5) Drive the machine backward and forward.  
Make sure the machine travels at slow speed.

## 2-9 Last Check

### Step 37

Retract the extension deck securely and lower the platform completely.

### Step 38

Put the machine on a firm level surface and turn the key switch to "OFF" (OFF) to shut down the machine.

### Step 39

Circle the machine and check visually that there are no oil leaks.

The pre-operation check is now complete.

# Chapter 7

## Operator Maintenance

### 1. Storage Method

After each use, store the machine as follows:

#### Step 1

Park the machine on a firm level surface.

#### Step 2

Retract the extension deck and lower the platform fully.

#### Step 3

Turn the key switch to "⊙" (OFF), and remove the key to prevent using the machine without permission, and store it suitably.

#### Step 4

Chock the wheels.

#### Step 5

Perform the daily maintenance.

### 1-1 Detaching Upper Controls

The upper controls of the machine can be detached to protect it from being stolen.

#### Step 1

Remove the cable from the upper controls.

#### Step 2

Cap both the connector of the cable and the connector of the upper controls.

#### Step 3

Remove the upper controls from the guardrails.

#### Step 4

Store the upper controls suitably.

## NOTICE

Failure to cap both connectors might wet connectors because of rain. This could cause the malfunction or the misoperation.

### 2. Daily Maintenance

## NOTICE

Only maintenance items that described in this manual can be done by the operator.

### 2-1 Hydraulic Oil Level Check

Maintaining the hydraulic oil at sufficient level is very important for the machine operation. Deficient of the hydraulic oil level can damage hydraulic parts. Daily checking the oil level can confirm the change of the hydraulic oil level that might show the hydraulic system problems.

#### Step 1

Park the machine on a firm level surface.

#### Step 2

Retract the extension deck and lower the platform fully.

#### Step 3

Turn the key switch to "⊙" (OFF).

#### Step 4

Look into the oil level sight hole (Fig. 7-1, A) located on the rear side of the machine. Check the oil level is within a range shown by arrows.

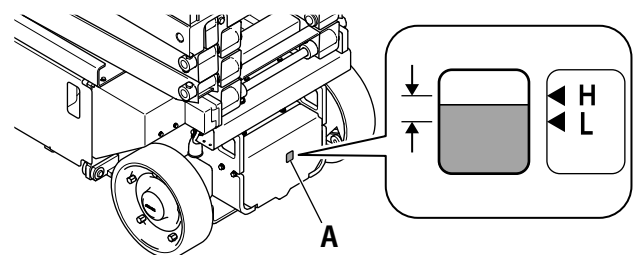

Fig. 7-1

M164L4-1

## 2-2 Battery Fluid Level Check

### **WARNING**

The battery fluid contains corrosive acid. When dealing with the battery, always wear appropriate protective clothing and equipment to protect your hands, eyes, face and body, and avoid contacting battery fluid.

### **CAUTION**

When opening/closing the battery boxes, take care not to pinch your hands.

### **NOTICE**

- Keep the terminals and the upper surface of the battery clean.
- If equipped with optional AGM batteries, there is no need to check the battery fluid levels.

Check the battery fluid levels every day (especially when using the machine in warm and dry climates).

#### Step 1

If the machine is charging batteries, remove the charging cable from the power outlet and store it in the designated place.

#### Step 2

Park the machine on a firm level surface in a well-ventilated, open area.

#### Step 3

Retract the extension deck and lower the platform fully.

#### Step 4

Turn the key switch to "O" (OFF).

#### Step 5

Open the battery box located on the left side of the machine.

1. Grasp lock levers on both sides of the battery box to unlock them.
2. Pull the battery box out with the levers grasped until it stops.

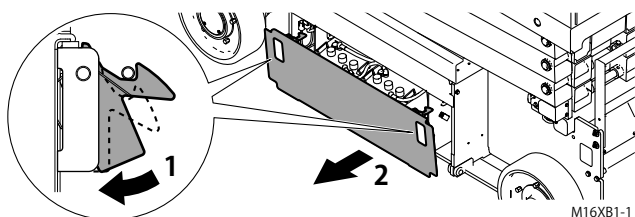

Fig. 7-2

### **NOTICE**

The battery box has two stop positions (except for stowage position): first stop position, for checking battery fluid levels; second stop position, for replacing batteries.

In order to pull the battery box out from first stop position to second stop position,

3. Lift up front side of the battery box.
4. Pull the battery box out about an inch with it lifted up (until it passes over the first stop position).
5. Pull open the battery box (until it reaches second stop position).

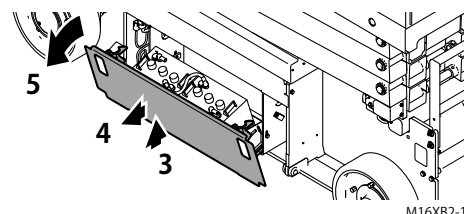

Fig. 7-3

#### Step 6

To cut off batteries electrically, disconnect the disconnecter (Fig. 7-4, A).

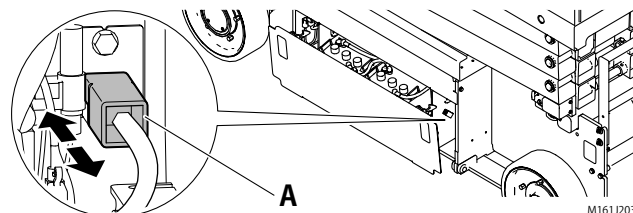

Fig. 7-4

#### Step 7

Remove the vent caps.

#### Step 8

Check the battery fluid level in each cell referring to Fig. 7-5.

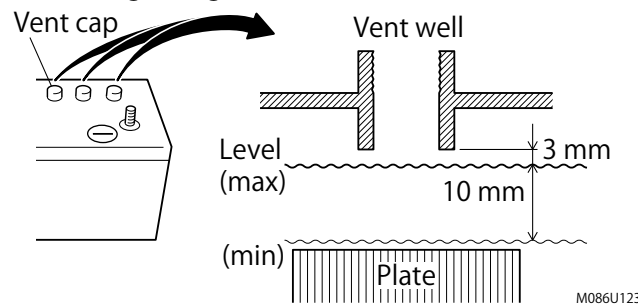

Fig. 7-5

**Step 9**

When the battery fluid level has dropped more than 10 mm, add only distilled water until the battery fluid level is 3 mm below the bottom of the fill well. (Fig. 7-5)

**! WARNING**

Do not overfill the water. Failure to comply will cause the battery to overflow acid, consequently causing a machine damage or fire.

**NOTICE**

The battery life will be shortened if anything other than distilled water is added.

**Step 10**

Keep the terminals and the upper surface of the battery clean.

**Step 11**

Secure vent caps back on the battery.

**Step 12**

Check the fluid levels of all batteries in the same manner.

**Step 13**

Open the battery box located on the right side of the machine and check the fluid levels of all batteries in the same manner.

**Step 14**

Connect the disconnecter (Fig. 7-6, A).

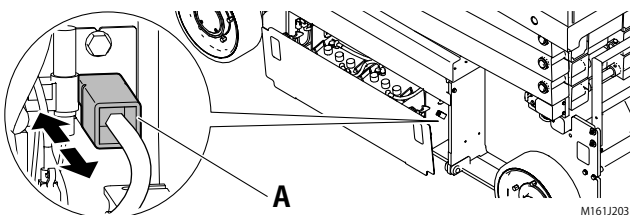

Fig. 7-6

**Step 15**

Close the right and left battery boxes and make sure they have been locked.

**2-3 Battery Charging****! WARNING**

- Charge in a well-ventilated, open area, away from open flames.
- Do not charge the battery when it has too little battery fluid, otherwise it will produce a poisonous gas, and there is possibility of serious injury, death and property damage, such as poisoning or metal corrosion. In this case, stop charging immediately.
- If equipped with optional AGM batteries, charge them only in combination with the battery charger built in the machine. Otherwise, leakage of electrolyte, heating, or explosion may result.

**NOTICE**



- Charge the batteries before discharging fully, otherwise the batteries will be damaged permanently.
- Do not charge the batteries continuously for more than two days.
- Do not disconnect the charging cable while charging.
- Always keep the charger dry.
- Rating of the charging cable provided is AC 250 V 10 A. Make sure the power outlet is AC 100-240 V.
- For the machine equipped with the flooded battery:  
At the battery fluid temperature of 20 °C, the normal specific gravity after charging is 1.26 or more.  

$$D_{20} = D_t + 0.0007 (t - 20)$$

$$D_{20} : \text{Specific gravity of the battery fluid calculated for } 20 \text{ } ^\circ\text{C}$$

$$D_t : \text{Actually measured specific gravity at a temperature of } t \text{ } ^\circ\text{C}$$

$$t : \text{Actually measured temperature of the battery fluid}$$
- The batteries will self-discharge little by little even when it is not in use. Charge the batteries every month even if the machine is not used.

- When the battery charger is working, the main power of the machine cannot be turned on even if the key switch is turned to either “” (UPPER CONTROLS) or “” (LOWER CONTROLS).

When only the “0 – 25%” red light in the battery level indicator is lit or flashing, or a day’s work is finished, charge the battery as follows.

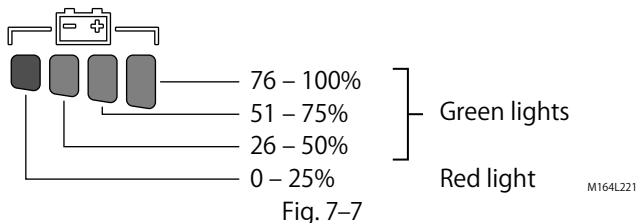

### Step 1

Park the machine on a firm level surface in a well-ventilated, open area.

### Step 2

Retract the extension deck and lower the platform fully.

### Step 3

Turn the key switch to “” (OFF).

### Step 4

For the machine equipped with the flooded battery, check the battery fluid levels.

### Step 5

Leave the battery box open for ventilation.

## NOTICE

Make sure to connect the disconnecter before charging. (Refer to “(8) Battery Disconnect System” under Section 1 of Chapter 3.)

### Step 6

Plug the charging cable (Fig. 7-8, A) into the power outlet.

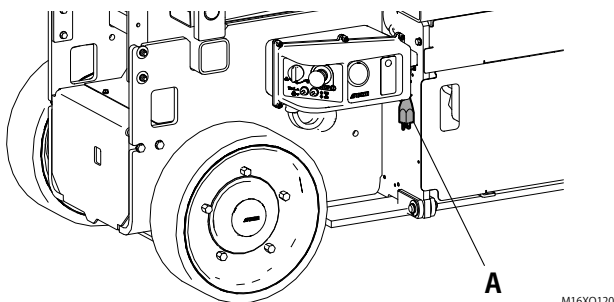

### Step 7

The battery charger indicator light (Fig. 7-9, A) will flash with green and the battery will start charging.

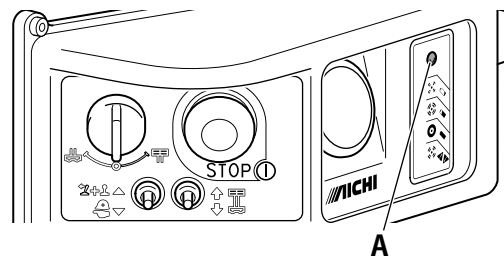

## NOTICE

If the battery charger indicator light flashes with yellow or red, refer to “6. Battery Charger Indicator Light” under Section 3 of Chapter 4 for the battery charger indications.

### Step 8

When charging is complete, the battery charger indicator light will turn on with green.

## NOTICE

The charging time is about 10 hours, though affected by many factors.

### Step 9

Close the battery box and make sure it has been locked.

## CAUTION



When closing the battery box, take care not to pinch your hand.

## 2-4 After Battery Charging

### Step 1

After charging is complete, remove the charging cable from the power outlet.

## NOTICE

- Unless the charging cable is removed from the power outlet, the main power of the machine does not turn on even if the key switch is turned to either “” (UPPER CONTROLS) or “” (LOWER CONTROLS).

- If the main power cannot be turned on even when the charging cable is removed, reconnect the charging cable to the power outlet. After confirming that the battery charger indicator light (Fig. 7-10, A) is illuminated or flashing, remove it again.

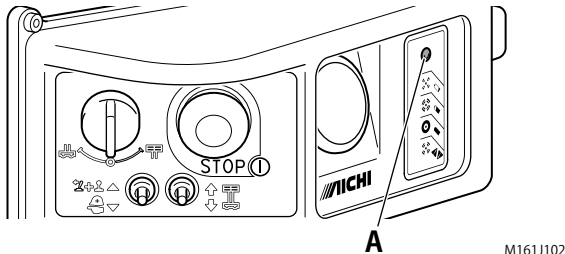

Fig. 7-10

M161J102

### Step 2

Store the charging cable in the designated place.

## 2-5 Tires and Wheels Check

Tires with worn edges, deformations or chippings of block require replacement. Immediately contact AICHI or an AICHI dealer for inspections.

## 3. Monthly Maintenance

### 3-1 Wear Pads Lubrication

Every 100 hours or 1 month, lubricate wear pads.

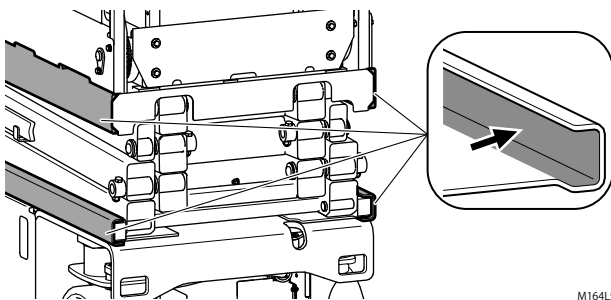

Fig. 7-11

M164L520

### **WARNING**

Whenever elevating the platform for lubricating, use the safety prop to avoid personal injury.

### **NOTICE**

Recommended grease: Shell Alvania EP Grease 2 or equivalent.

### Step 1

Park the machine on a firm level surface.

### Step 2

Retract the extension deck and lower the platform fully.

### Step 3

Refer to Section 2 of Chapter 3 and set up the safety prop.

### Step 4

Apply a thin layer of grease along inside of both the upper and lower slide guides on both sides of the machine, where the wear pads make contact.

## 3-2 Pothole Protector Lubrication

Every 100 hours or 1 month, lubricate pothole protector mechanism.

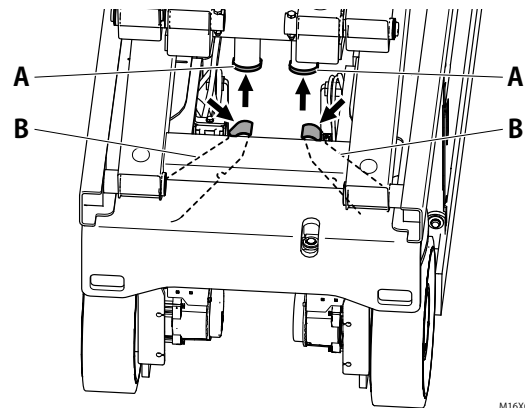

Fig. 7-12

M16XC120

### **WARNING**

Whenever elevating the platform for lubricating, use the safety prop to avoid personal injury.

### **NOTICE**

Recommended grease: Shell Alvania EP Grease 2 or equivalent.

### Step 1

Park the machine on a firm level surface.

### Step 2

Retract the extension deck and lower the platform fully.

### Step 3

Refer to Section 2 of Chapter 3 and set up the safety prop.

### Step 4

Apply a thin layer of grease on contacting surface between the pothole actuators (Fig. 7-12, A) and the pothole links (Fig. 7-12, B).

# Chapter 8

## Operation

### **⚠️ WARNING**

- Perform pre-operation checks before operating the machine, and make sure there are no problems with the machine.
- For emergencies, read and understand Chapter 9 "Emergency Operation" before operating the machine.

### **NOTICE**

The motion alarm buzzer sounds when the machine is in motion to warn to the people nearby.

## 1. Lower Controls (from Ground)

### Step 1

Pull out the emergency stop button on both the lower controls and the upper controls.

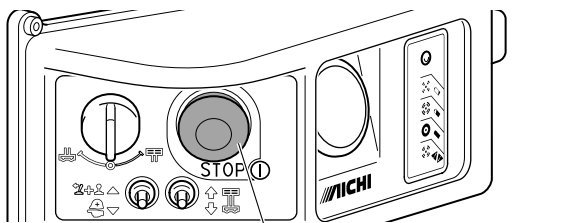

Emergency Stop Button  
Fig. 8-1 (Lower Controls)

M161J623

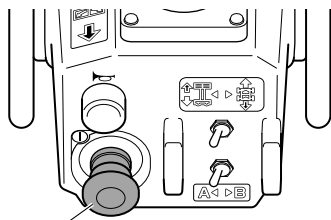

Emergency Stop Button  
Fig. 8-2 (Upper Controls)

M164L631

### Step 2

Turn the key switch to "LOWER CONTROLS".

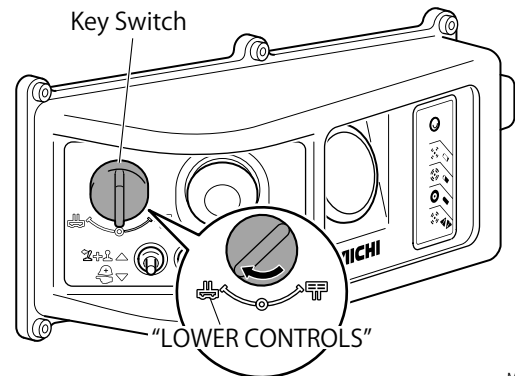

Fig. 8-3

M161T13-2

### Step 3

Check the multi-function indicator and make sure that the battery is sufficiently charged.

## 1-1 Raising and Lowering Platform

### **⚠️ WARNING**

Only raise the platform on a firm, level, and smooth surface, free of obstructions and holes.

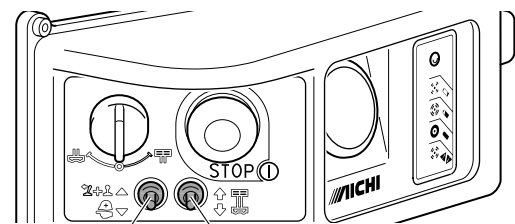

Enable Switch Lift Switch  
Fig. 8-4

M166T332

### Step 1

Hold the enable switch up.

### Step 2

Operate the lift switch to "RAISE" or "LOWER."

### **NOTICE**

Releasing the enable switch will stop the function being operated.



**Step 3**

Reduce the load if the diagnostic code "LMT 005" appears on the multi-function indicator when lifting the platform.

**NOTICE**

- For SV06ENL, SV08ENL, and SV10EWL, the maximum platform capacity varies with the selection of the capacity select switch on the upper controls.
- The platform automatically stops lowering when it is lowered to a height below from ground:
  - approx. 1.5 m (SV06ENS/SV06ENL)
  - approx. 1.8 m (SV08ENL)
  - approx. 2.0 m (SV08EWL/SV10EWL)

Release all switches. Make certain the area under the platform is clear of all obstructions and personnel, then continue to lower the platform. (The platform does not lower for 3 seconds after releasing the switches.)

**2. Upper Controls (from Platform)**

**Step 1**

Pull out the emergency stop button on both the lower controls and the upper controls.

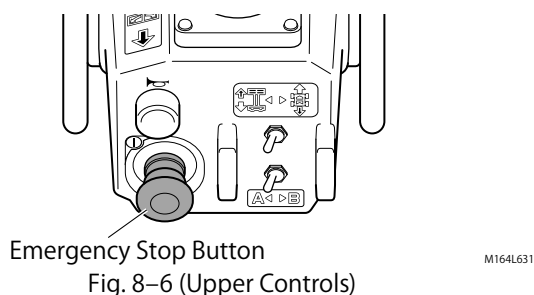
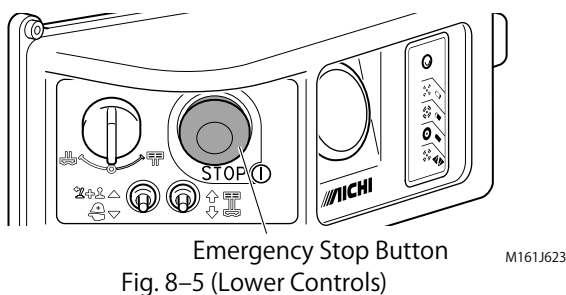

**Step 2**

Turn the key switch to "UPPER CONTROLS".

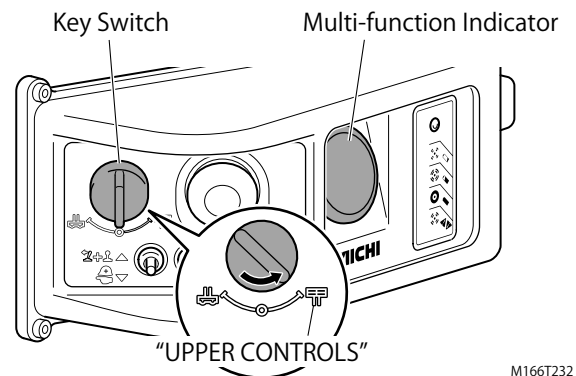

Fig. 8-7

**Step 3**

Check the multi-function indicator and make sure that the battery is sufficiently charged.

**Step 4**

Get on the platform and close gate. If wearing the safety harness, after getting on the platform, immediately attach the lanyard of the safety harness to the specified lanyard anchorage point.

**2-1 Raising and Lowering Platform**

**WARNING**

Only raise the platform on a firm, level, and smooth surface, free of obstructions and holes.

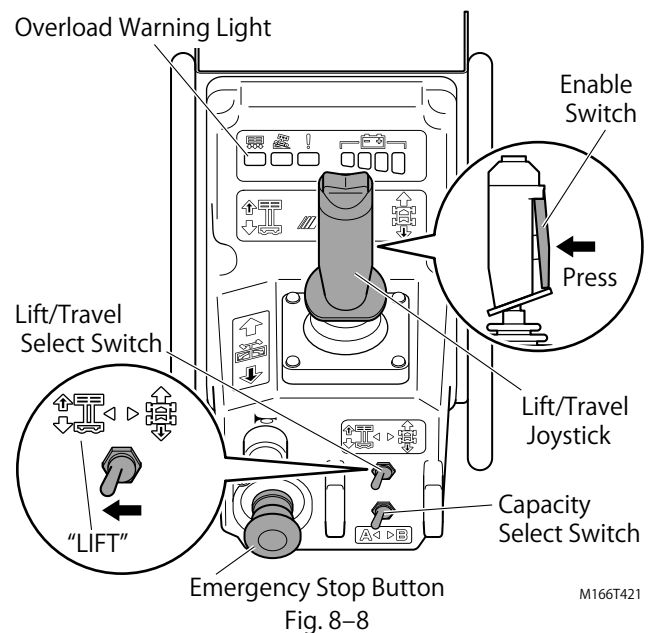

**Step 1**



Turn the lift/travel select switch to "LIFT".

### Step 2

(For SV06ENL, SV08ENL, and SV10EWL)

Select the desired capacity zone using capacity select switch.

**Table 8-1 For SV06ENL**

Zone	Platform Capacity	Max. Persons
 Indoor	360 kg or less	2
 Outdoor	230 kg or less	1

**Table 8-2 For SV08ENL**

Zone	Platform Height	Platform Capacity
A	0 – 6.00 m	360 kg or less
B	0 – 7.77 m	230 kg or less

**Table 8-3 For SV10EWL**

Zone	Platform Height	Platform Capacity
A	0 – 7.90 m	450 kg or less
B	0 – 9.68 m	320 kg or less

### Step 3

Press the enable switch.

### Step 4

Operate the lift/travel joystick controller to "RAISE" or "LOWER."

## NOTICE

Releasing the enable switch will stop the function being operated.

### Step 5

Reduce the load if the overload warning light goes on when lifting the platform.

## NOTICE

- For SV06ENL, SV08ENL, and SV10DWL, the maximum platform capacity varies with the selection of the capacity select switch.
- The platform automatically stops lowering when it is lowered to a height below from ground:
  - approx. 1.5 m (SV06ENS/SV06ENL)
  - approx. 1.8 m (SV08ENL)
  - approx. 2.0 m (SV08EWL/SV10EWL)

Release all switches. Make certain the area under the platform is clear of all obstructions and personnel, then continue to lower the platform. (The platform does not lower for 3 seconds after releasing the switches.)

## 2-2 Traveling

### ⚠ WARNING

Do not travel with the platform elevated except on a firm, level, and smooth surface, free of obstructions and holes.

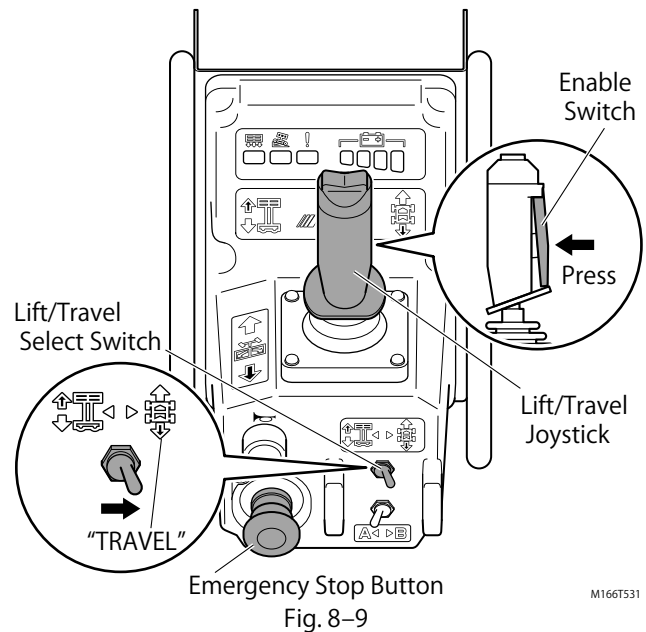

### Step 1

Turn the lift/travel select switch to "TRAVEL".

### Step 2

Press the enable switch.

### Step 3

Operate the lift/travel joystick controller to "FORWARD" or "BACKWARD."

## NOTICE

- The drive system of the machine is proportional. To increase the traveling speed, operate the joystick controller further in the direction of travel.
- Releasing the enable switch will stop the function being operated.

## 2-3 Steering

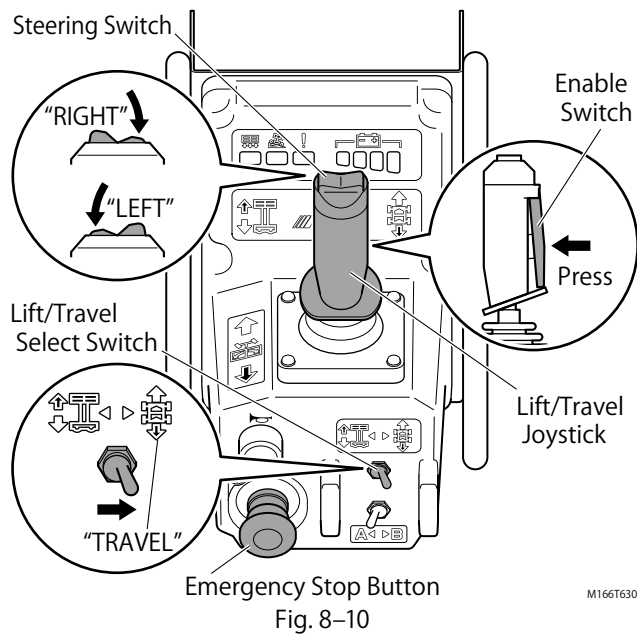

Fig. 8-10

### Step 1

Turn the lift/travel select switch to "TRAVEL".

### Step 2

Press the enable switch.

### Step 3

Press the steering switch to "RIGHT" or "LEFT." Then steer wheels should turn right or left. This operation is possible even when traveling.

### Step 4

Even when the steering switch is returned to neutral, steer wheels will not return to center position. Operate the steering switch in the opposite direction until the wheels are returned to center position.

## NOTICE

Releasing the enable switch will stop the function being operated.

## 3. Extension Deck

### ⚠ DANGER

Make sure the extension deck has locked before operating the machine. Unlocked extension deck may move accidentally. Such an accident increases the potential of fall hazards.

### ⚠ CAUTION

Do not extend or retract the extension deck when the machine is on a slope. Failure to follow this instruction could result in personal injury or property damage due to unexpected movement of the extension deck.

## NOTICE

When extending/retracting the extension deck, do not twist the handles. Push/pull the handles straight without putting a force in any direction other than forward/backward.

## 3-1 Extending

### Step 1

Make sure that the slack (Fig. 8-11, C) of the spiral cable (Fig. 8-11, B) is positioned in this side of the cable hanger (Fig. 8-11, A) as shown in the figure below.

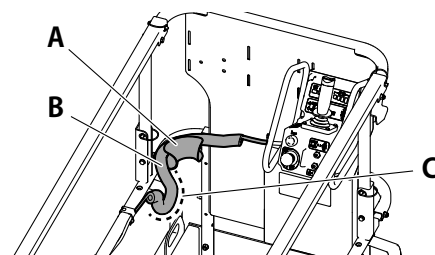

Fig. 8-11

M166V220

### Step 2

Get on the side of the platform that does not have the extension deck.

**Step 3**

Turn the handles (Fig. 8-12, A), located on the left and right sides of the guardrails, toward the inside until they stop (Fig. 8-12, 1). The extension deck is now unlocked.

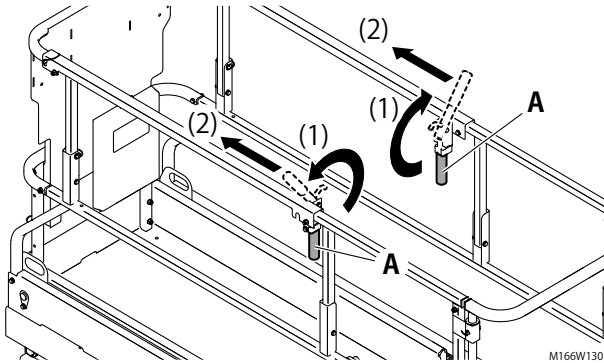

Fig. 8-12

**Step 4**

While holding the handles, push the deck forward until it stops. (Fig. 8-12, 2)

**Step 5**

Turn the handles (Fig. 8-13, A) to their original positions (Fig. 8-13, 3).

The extension deck is now locked.

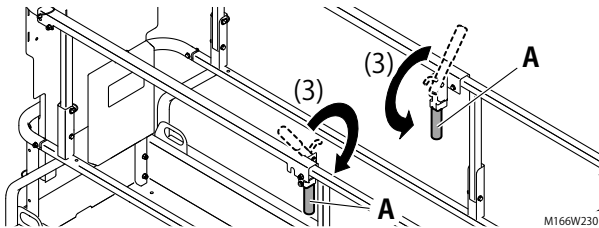

Fig. 8-13

**NOTICE**

The extension deck has three lock points. The lock points are marked on the left side of the toe-board with red arrows (Fig. 8-14, A).

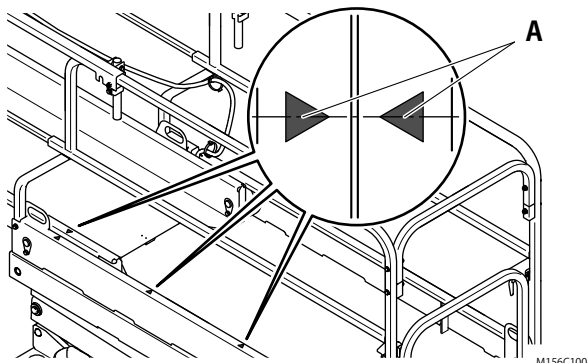

Fig. 8-14

**3-2 Retracting**

**Step 1**

Get on the side of the platform that does not have the extension deck.

**Step 2**

Turn the handles, located on the left and right sides of the guardrails, toward the inside until they stop.

The extension deck is now unlocked.

**Step 3**

While holding the handles, pull the deck backward until it stops.

**Step 4**

Turn the handles to their original positions.

The extension deck is now locked.

**Step 5**

After retracting the extension deck, make sure that the slack (Fig. 8-15, C) of the spiral cable (Fig. 8-15, B) is positioned in this side of the cable hanger (Fig. 8-15, A) as shown in the figure below.

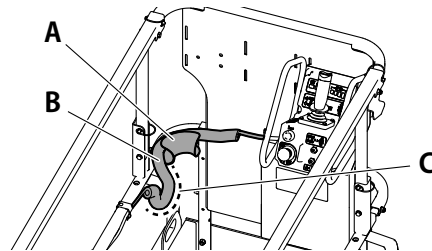

Fig. 8-15

## 4. Fold Down Guardrails

(For all models except SV06ENS)  
(For SV06ENS if so equipped)

The platform guardrails may be lowered approx. 280 mm, which is useful for limited head clearance or transportation.

### **! DANGER**

Using the machine with the guardrails folded increases the potential for hazards, which could result in death or serious injury. Do not raise the platform with the guardrails folded. Take extreme care when driving the machine with the guardrails folded.

### **! CAUTION**

- Do not fold down or raise the guardrails when the machine is on a slope. Failure to follow this instruction could result in personal injury or property damage due to unexpected movement of the extension deck.
- Take extreme care when getting on and off the platform after the guardrails have been folded down.

### 4-1 Folding Down Guardrails

Fold down the platform guardrails according to the following procedure. It should be done with more than one person.

#### Step 1

Lower the platform completely.

#### Step 2

Make sure to lock the extension deck.

#### Step 3

Close and lock the platform entry gate.

#### Step 4

Remove optional equipment installed on rails of the guardrail system, such as the work light.

#### Step 5

Remove the spiral cable (Fig. 8-16, B) from the cable hanger (Fig. 8-16, A).

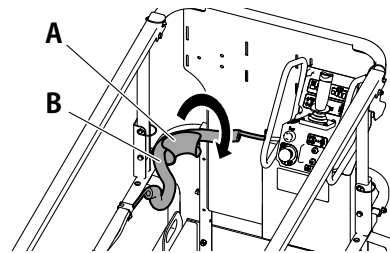

Fig. 8-16

M166V120

#### Step 6

Pull out the lock pin (Fig. 8-17, B) of the upper control box (Fig. 8-17, A).

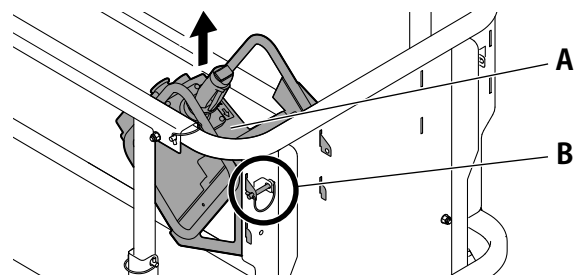

Fig. 8-17

M166U020

#### Step 7

Remove the upper control box from the guardrails and lay it down on the platform floor.

#### Step 8

Remove the lock pin (Fig. 8-18, B) that locks the front vertical rails.

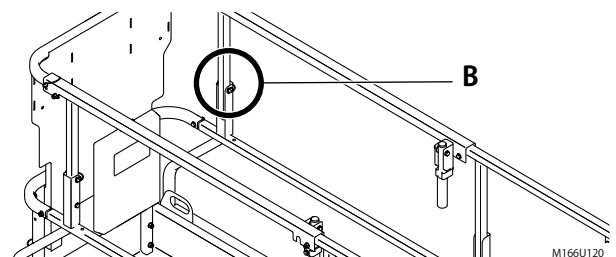

Fig. 8-18

M166U120

#### Step 9

Install the lock pin that is removed in Step 8 to secure the extension deck. Refer to figure below for installation point.

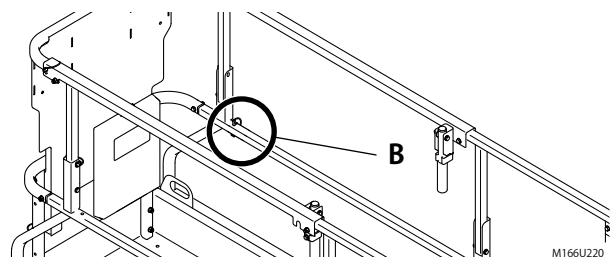

Fig. 8-19

M166U220

**Step 10**

Remove the lock pin (Fig. 8-20, B) that locks the top rails of the guardrails.

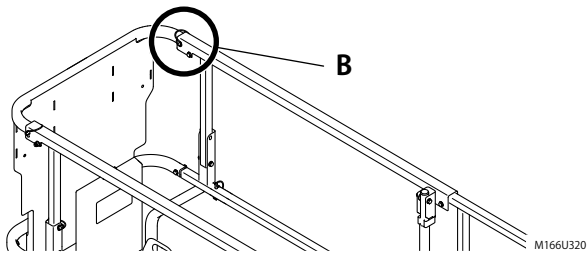

Fig. 8-20

**Step 11**

Turn the handle (Fig. 8-21, A) located on the right (or left) side of the guardrails, toward inside until it stop. (Fig. 8-21, 1)

The top rail (Fig. 8-21, C) is now unlocked.

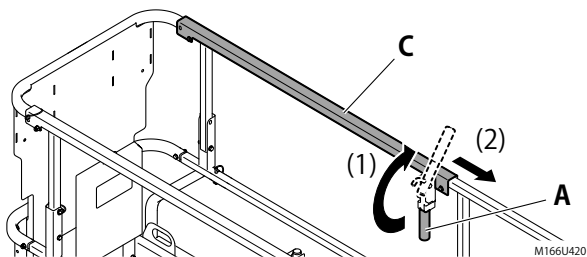

Fig. 8-21

**Step 12**

Pull the handle backward to slide the top rail until it stop (approx. 2 inches). (Fig. 8-21, 2)

**Step 13**

Turn the handle (Fig. 8-22, A) to its original position. (Fig. 8-22, 3)

The top rail is now locked.

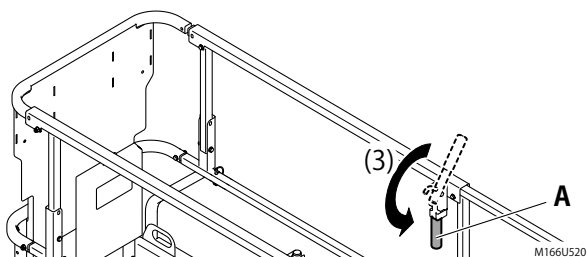

Fig. 8-22

**Step 14**

After sliding one side of the top rail, slide the other side in the same manner. (Refer to the steps from Step 8 to Step 13.)

**Step 15**

Remove the lock pins (Fig. 8-23, B) that lock the guardrail slide bar (Fig. 8-23, D).

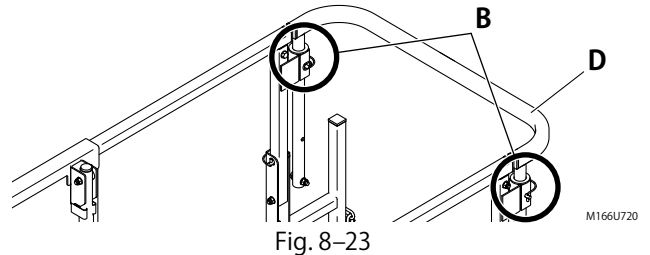

Fig. 8-23

**Step 16**

Pull out the short side of the slide bar (Fig. 8-24, D) from the bracket (Fig. 8-24, E).

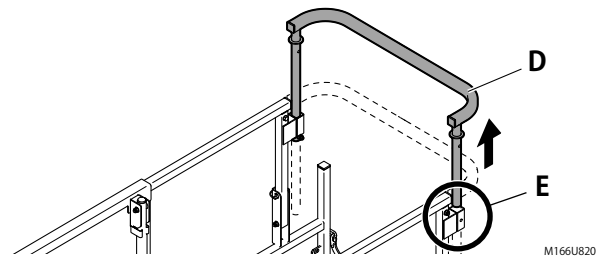

Fig. 8-24

**Step 17**

Remove the lock pin (Fig. 8-25, B) located on the left side of the guardrails.

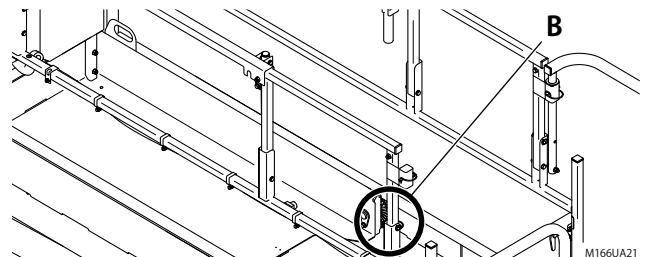

Fig. 8-25

**Step 18**

Fold down the left side of the guardrails (Fig. 8-26, C).

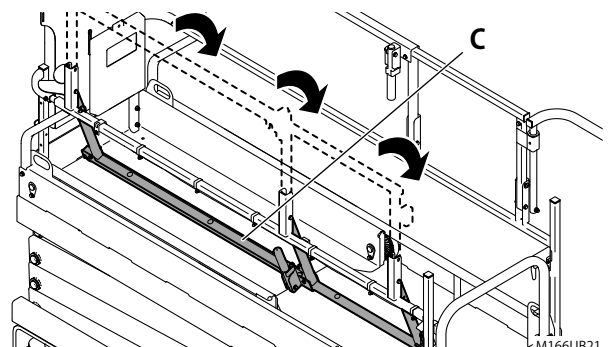

Fig. 8-26

**Step 19**

Rotate the gate (Fig. 8-27, F) and hook it on the folded left side guardrail as show in a figure below.

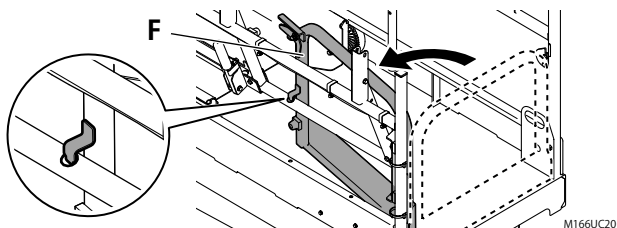

Fig. 8-27

**Step 20**

Rotate and position the slide bar (Fig. 8-28, D) in figure below.

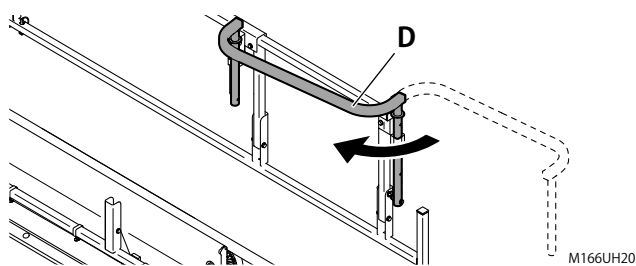

Fig. 8-28

**Step 21**

Remove the lock pin (Fig. 8-29, B) located on the right side of the guardrails.

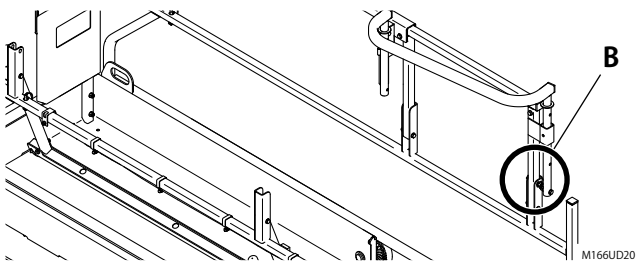

Fig. 8-29

**Step 22**

Hold the slide bar while folding down the right side of the guardrails (Fig. 8-30, C).

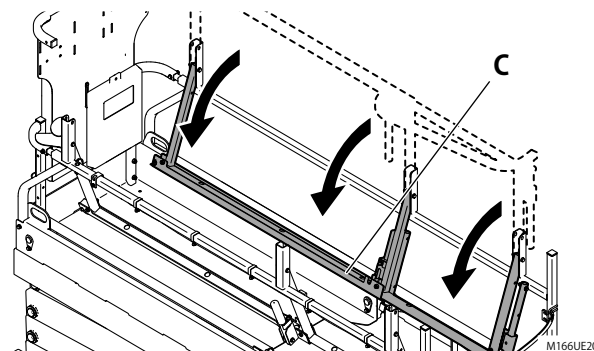

Fig. 8-30

**NOTICE**

Move the slide bar to avoid interference with the middle rail of the guardrails while folding down the guardrails.

**Step 23****CAUTION**

Hold the front part of the guardrails while removing the lock pins to prevent it from folding down.

Remove the lock pins (Fig. 8-31, B) located on the front part of the guardrails.

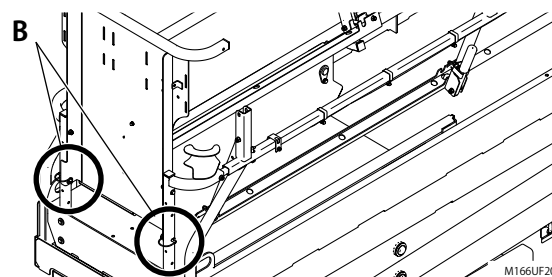

Fig. 8-31

**Step 24**

Fold down the front part of the guardrails (Fig. 8-32, G).

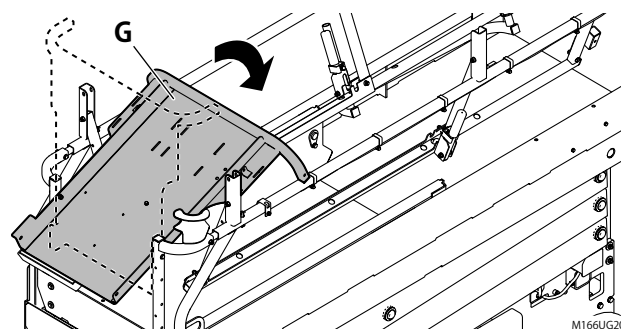

Fig. 8-32

## 4-2 Raising Guardrails

In order to put the guardrails back to the original position, perform the procedure backwards.

### **! DANGER**

Make sure the fold down guardrails have been raised and locked before operating the machine. The fold down guardrails which are not locked may move accidentally. Such an accident increases the potential of fall hazards.

### **! CAUTION**

- Do not fold down or raise the guardrails when the machine is on a slope. Failure to follow this instruction could result in personal injury or property damage due to unexpected movement of the extension deck.
- Take extreme care when getting on and off the platform after the guardrails have been folded down.

### **NOTICE**

After installing the upper control box, hang the spiral cable (Fig. 8-33, B) on the cable hanger (Fig. 8-33, A) so that the slack (Fig. 8-33, C) of the cable is positioned in this side as shown in the figure below.

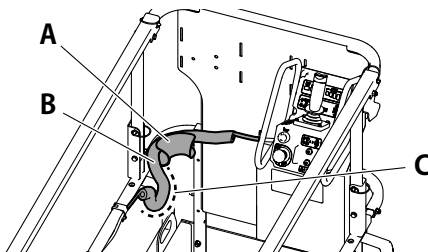

Fig. 8-33

M166V220



# Chapter 9

## Emergency Operation

### NOTICE

If the emergency operation was done because of a malfunction, immediately stop the operation, and have the machine checked and repaired.

### 1. Emergency Stop

Use the emergency stop button. When the emergency stop button is pushed in, all of the functions are disabled. Push in the emergency stop button in the following cases:

1. When personnel on the platform stops all of the machine movements to avoid hazard.
2. When the personnel on the ground judges that the operation from the platform is unsafe.
3. When the machine is uncontrollable due to malfunction.
4. When performing the emergency lowering procedure to lower the platform.

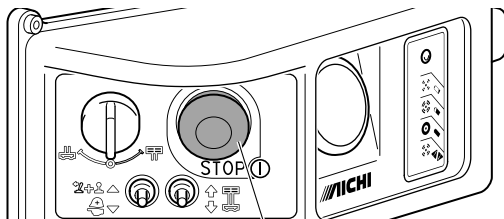

Emergency Stop Button  
Fig. 9-1 (Lower Controls)

M161J623

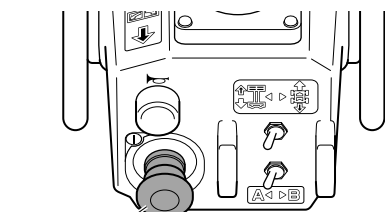

Emergency Stop Button  
Fig. 9-2 (Upper Controls)

M164L631

### 2. Emergency Lowering

If the platform has been raised, and it is not possible to lower it because of power source failure, e.g., a dead battery, or because the upper emergency stop button has been pressed, do the following:

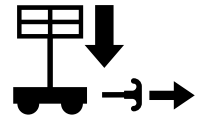

### WARNING

Do not put your body or any object between scissor arms. Failure to avoid this hazard could result in death, serious injury or property damage.

#### Step 1

Shut down the machine by pushing in the emergency stop switch. (Alternatively turning off the key switch.)

#### Step 2

Make sure that there are no people and/or objects under the platform.

#### Step 3

The emergency lowering handle is located at the rear side of the machine (Fig. 9-3, A). Pull the handle outward and lower the platform.

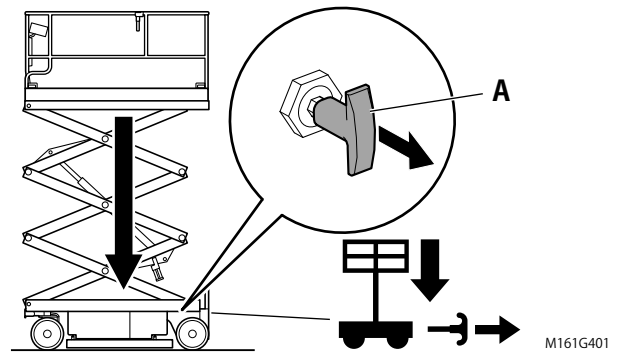

Fig. 9-3

M161G401

#### Step 4

To stop lowering, release the emergency lowering handle.

# Chapter 10

## Transporting

### **⚠️ WARNING**

Be sure the transport vehicle capacity, crane capacity, loading surfaces, ramps, sling chains and wire ropes are sufficient to withstand the machine weight. See the serial number plate for the machine weight.

### **NOTICE**

- This information about transporting is offered as a recommendation.
- Only the qualified persons shall use the transport vehicle, crane, forklift, and the machine.
- All persons on transportation must comply with employer, work area, and local and national safety regulations regarding the use of these machinery.
- Each machinery must comply with all applicable regulations, and must be inspected and used in accordance with their manufacturer's instructions.
- It is the carrier's responsibility to perform proper loading/unloading, tie-down, lift, hoist and transportation.

### 1. Preparation for Transporting

When transporting the machine by a transport vehicle, observe the following items:

#### Step 1

Park the transport vehicle on a firm level surface for loading/unloading the machine to/from the transport vehicle.

#### Step 2

Chock the wheels of the transport vehicle. (Fig. 10-1, A)

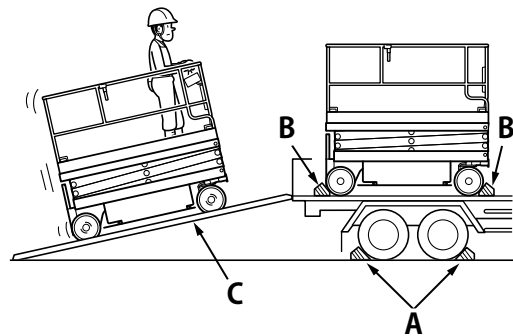

Fig. 10-1

M0851A04

#### Step 3

Lower the platform completely, and retract and lock the extension deck.

Bind the lock handles to each holder by cable ties, etc. to prevent the lock handles from unexpected release because of vibration.

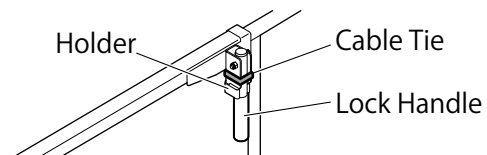

Fig. 10-2

M079D420

#### Step 4

Remove all loose items from the machine and transport vehicle bed.

#### Step 5

Check the entire machine for loose bolts, and unfastened locks.

## 2. Loading/Unloading

### **WARNING**

- Do not drive the machine on a slope that exceeds the machine gradeability.
- If the transport vehicle and the loading ramp are inclined to the left or right excessively, the wheels of the machine may fall off the ramp.
- Do not turn the steering of the machine while it is on the ramps, because of the possibility of a fall.
- Use a winch for loading/unloading, if the ramp is too steep or slippery.
- When loading/unloading, be sure to have a guide assist you so that the wheels do not fall off the ramps and the transport vehicle bed.
- Failure to avoid these fall hazards could result in death or serious injury.

#### Step 1

Attach the loading ramps at as small an angle as possible. (Fig. 10-1, C)

#### Step 2

Drive the machine straight forward/backward at low speed onto the ramps, and load/unload the machine onto/from the transport vehicle.

### **NOTICE**

- The machine automatically changes the travel mode according to the tilt of the machine. Therefore, the machine may stop or move back for a moment when the machine suddenly tilts during traveling. Stop once before going up onto the ramp.
- The backward traveling has a slightly higher gradeability than the forward traveling. Try traveling backward if hard to travel forward onto ramps.
- If a front (drive) wheel is spinning, the system failure light may flash and the machine may stop traveling. In this case, release all controls or power cycle the machine. (See Chapter 12, Section 2, "ERR 809".)

#### Step 3

Shut off the machine and chock the wheels of the machine. (Fig. 10-1, B)

## 3. Tie Down

### Step 1

Pass the tie down chains or wire ropes through all the tie down eyes (Refer to Fig. 10-3).

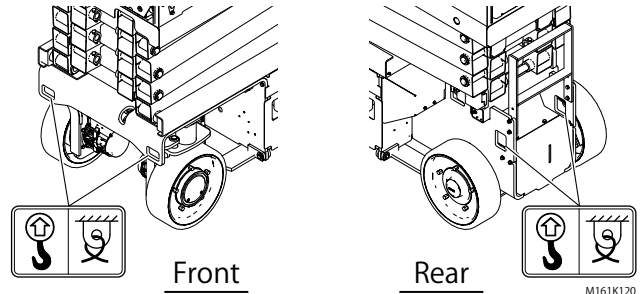
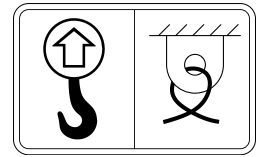

Fig. 10-3

### **NOTICE**

Do not pass the tie down chains or wire ropes through any part of the machine except designated tie down eyes. Failure to obey this instruction could result in the machine damage.

### Step 2

Tie down the machine on the vehicle bed securely. (Refer to Fig. 10-4)

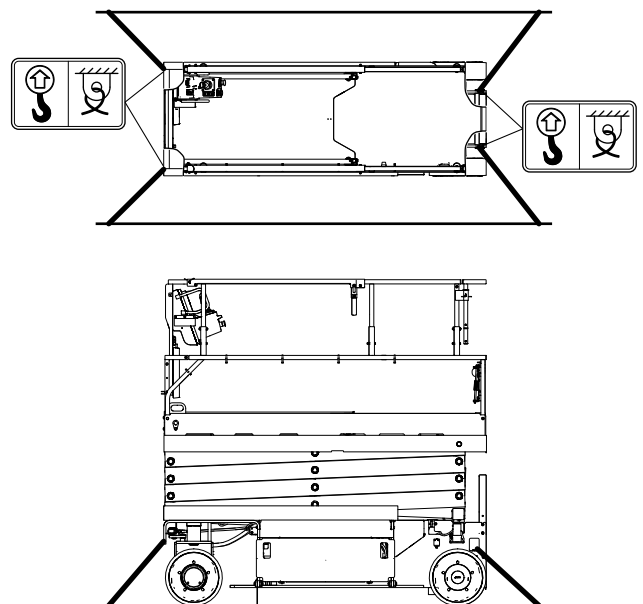

Fig. 10-4

### **NOTICE**

Tighten the tie down chains or wire ropes just so that the machine does not bounce during transportation. Overtightening could result in the machine damage.

## 4. Hoisting

More than  
2.0 m (SV06ENS)  
/ 2.5 m (SV06ENL/SV08ENL)

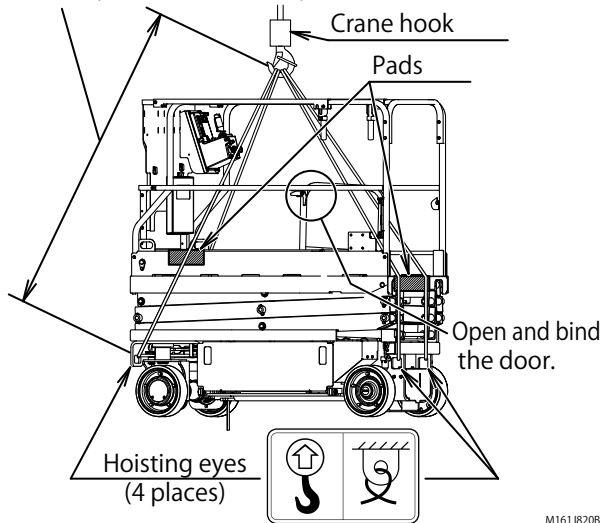

Fig. 10-5

More than  
2.8 m (SV08EWL/SV10EWL)

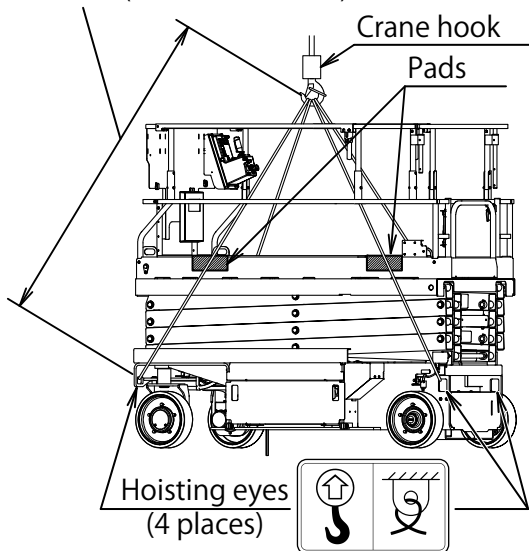

Fig. 10-6

### Step 1

Lower the platform completely, and retract and lock the extension deck.

### Step 2

Use 4 sling chains or wire ropes of the same length. (Refer to Fig. 10-5 and Fig. 10-6 for length)

### Step 3

Attach the sling chains or wire ropes firmly, e.g., with shackles, to all the hoisting eyes.

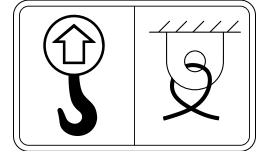

## NOTICE

- If the sling chains or wire ropes are in contact with the platform or an area around the lifting eyes on the chassis frame, place pads on the area to protect it.
- In some shackles might be in contact with the steering device. In this case, change to suitable shackles to prevent interference.

### Step 4

Adjust the sling chains or wire ropes and the hoisting attachments to prevent damage to the machine and to keep the machine level.

## WARNING

- Do not allow any person to get under the machine while hoisting.
- Do not pass the sling chains or wire ropes except designated hoisting eyes.
- Failure to heed warnings could result in breaking, falling, or other hazards leading to death or serious injury.

## NOTICE

For the machine with the door type entry gate; open the door and bind it by cable ties, etc. before hoisting the machine.

## 5. Lifting with Forklift

If a forklift is used, there are marks on the machine. Adjust the 2 forklift forks to the marks and insert.



If lifting the machine from the side, insert the forks into within a range shown by arrow A in the figure below. Adjust the forklift forks as wide as possible.

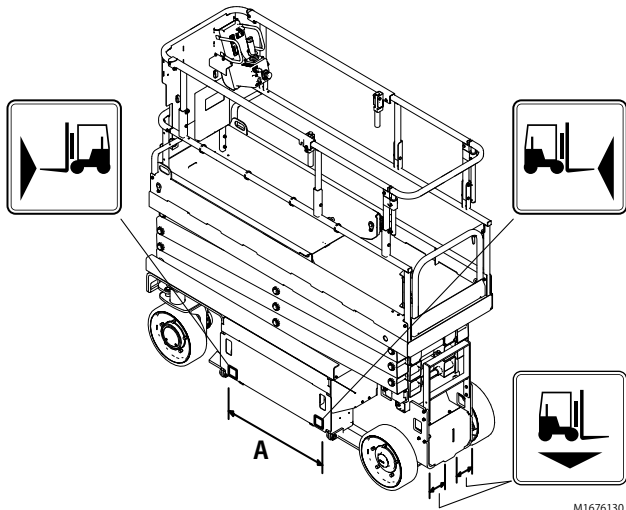

Fig. 10-7

M1676130

### **WARNING**

Insert the forklift forks at the marks.

There is hazard of the machine falling, and of damage to the machine. Failure to avoid this hazard could result in death or serious injury.

### **NOTICE**

When inserting the forklift forks from the side of the machine, avoid interference with the antistatic strap

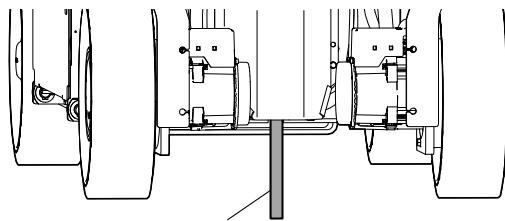

Antistatic Strap

Fig. 10-8

M16XH120

# Chapter 11

## Storage

1. Clean each part.

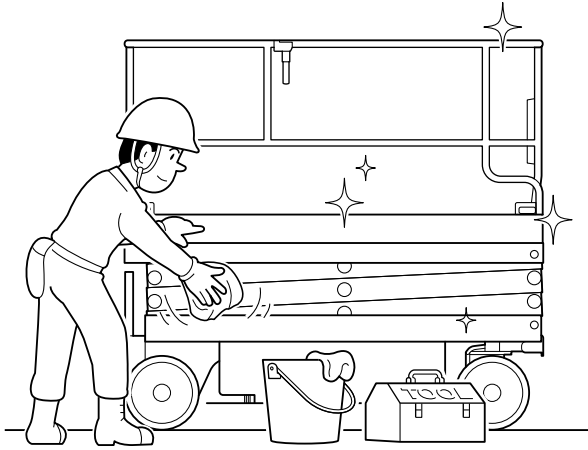

Fig. 11-1

M0851502

### NOTICE

Be careful about freezing in winter.

2. Wipe away dirt from around the electrical parts with a dry cloth.

### NOTICE

Do not wash, particularly high-pressure washing, around the electrical parts.

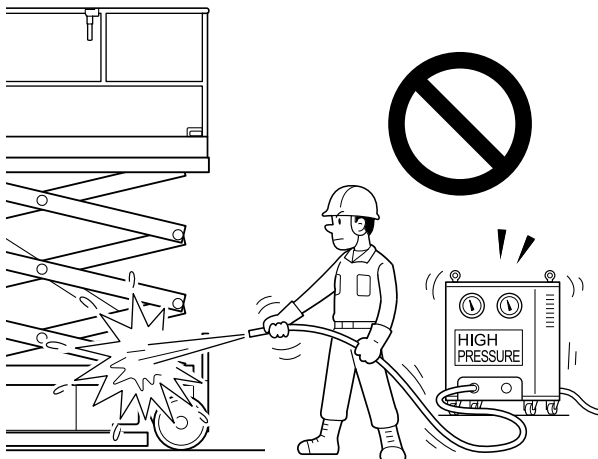

Fig. 11-2

M0851622

3. Grease each part.

Apply enough rust-prevention oil to the cylinder rod of the steering cylinder.

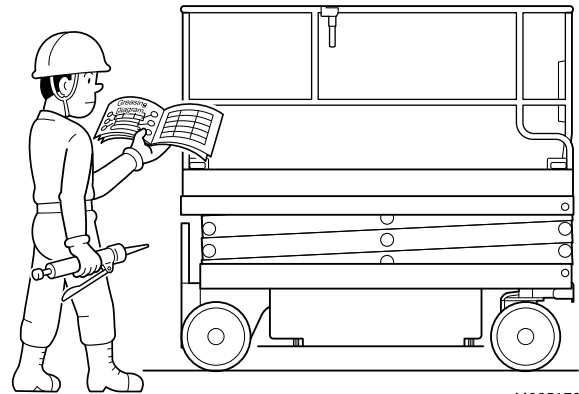

Fig. 11-3

M0851702

4. Disconnect the disconnecter (Fig. 11-4, A) to cut off batteries electrically. If needed, remove batteries from the machine and cover them.

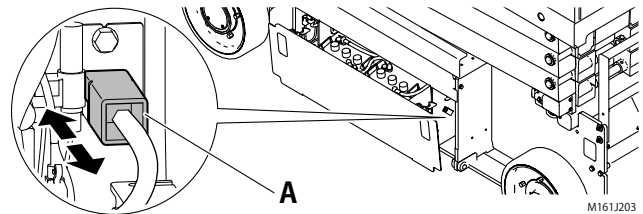

Fig. 11-4

M161203

### CAUTION

- Before removing batteries, disconnect the disconnecter.
- When finishing battery installation, connect the disconnecter last.

- To prevent overdischarging, charge the battery every month.

## NOTICE

The battery will self-discharge little by little even when it is not in use. If it is not charged for a long time, it will become over-discharged, and this will shorten the battery life.

- In order to prevent rust when the machine is stored for a long time, operate the machine every month to prevent the loss of the oil layer on lubricated parts.

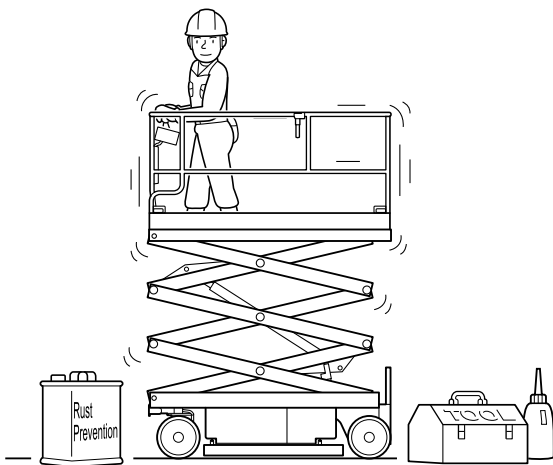

M0851922

Fig. 11-5

## NOTICE

- Before operating the machine, wipe off the rust prevention oil that had been applied to the cylinder rod.
  - After operating the machine, apply rust-prevention oil to the cylinder rod again.
- When the machine is left too long in the same place, the tread (the spot of the tire in contact with the ground) flattens as it is pressed against the flat surface. The flat-spots can cause a shimmy or harmonic vibration.

## NOTICE

The flat-spots recover in about 1 week after releasing the load on these spots, and then the vibration disappears.

- Storage in cold environments (less than 0 °C)  
Avoid locations where freezing temperatures are anticipated during storage.

## NOTICE

The batteries can freeze in cold temperatures if they are not fully charged. If the batteries are stored during cold winter months, it is important that they are kept fully charged.

# Chapter 12

## Troubleshooting

### 1. Battery Charger Fault Codes

If a fault occurs during charging, the battery charger indicator light on the lower controls will flash in red.

Count the number of red flashes between pauses and refer to the table below for remedy.

**Table 12-1 Battery Charger Fault Codes**

Red Flashes	Description	Remedy
Once	Battery High Voltage	Check battery size and condition. This fault will automatically clear once the condition has been corrected.
Twice	Battery Low Voltage	Check battery size and condition. This fault will automatically clear once the condition has been corrected.
3 times	Charge Timeout caused by battery pack not reaching required voltage. Charger output was reduced due to high temperatures.	Check connections. Operate charger at a lower ambient temperature. Reset charger (interrupt AC power for 15 seconds).
4 times	Check Battery: battery could not be trickle charged up to minimum voltage.	Check for shorted or damaged cells. Reset charger (interrupt AC power for 15 seconds).
5 times	Over-Temperature: Charger shut down due to high internal temperature.	Ensure sufficient cooling air flow and reset charger (interrupt AC power for 15 seconds).
6 times	Charger Internal Fault	Reset charger (interrupt AC power for 15 seconds). Return to qualified service depot if fault persists.

### 2. Diagnostic Codes Chart

When a problem occurs, a diagnostic code such as "LMT" or "ERR" will appear on the digital display, and then three digit number related to the diagnostic code will appear.

For further information of the diagnostic code and number, refer to table below.

**Table 12-2 Diagnostic Codes Chart**

Code	Number	Description	Causes	Remedy
LMT	001	Platform elevation and Travel Prevented on slope	The machine is tilted more than specified tilt angle and the platform is elevated more than specified height.	• Lower the platform until the alarm buzzer stops.
LMT	002	Platform elevation Prevented on slope	The machine is tilted more than specified tilt angle.	• Lower the platform and move to a level surface to elevate the platform.
LMT	003	(For SV08ENL and SV10EWL) Platform elevation Prevented, Max. platform height in Zone A	The platform has reached the maximum platform height when the capacity select switch is selected in Zone A.	• Check that the capacity select switch is selected appropriately for the platform load. When the platform load is less than rated load for Zone B, you can turn the capacity select switch to Zone B to elevate the platform furthermore.



Table 12-2 Diagnostic Codes Chart (Continued)

Code	Number	Description	Causes	Remedy
LMT	004	(For SV08ENL and SV10EWL) Platform elevation Prevented, Overreached in Zone A	The platform has overreached the maximum platform height when the capacity select switch is selected in Zone A.	<ul style="list-style-type: none"> <li>Lower the platform and check that the platform load is appropriately for the rated load for Zone A. When the platform load is less than rated load for Zone B, you can turn the capacity select switch to Zone B to continue to operate the machine.</li> </ul>
LMT	005	Platform elevation and Travel Prevented, Platform overloaded	The platform has been overloaded.	<ul style="list-style-type: none"> <li>Reduce the load on the platform.</li> </ul>
LMT	006	Platform lowering Prevented in Pre-operation check mode	The pre-operation check switch is turned on.	<ul style="list-style-type: none"> <li>Release the pre-operation check switch.</li> </ul>
LMT	008	Platform elevation and Travel Prevented, Pothole protector not deployed	The pothole protectors are stuck and do not deployed.	<ul style="list-style-type: none"> <li>Check the pothole protectors for stuck.</li> </ul>
LMT	012 013 014 015	Over-Temperature	Temperature of machine component is too hot.	<ul style="list-style-type: none"> <li>Turn off the key switch and leave the machine until temperature is decreased.</li> </ul>
LMT	211 212 213 221 222 223	Operation Time-out	None of the functions is operated for more than 20 seconds after operating the enabler switch, or The enable switch is not operated for more than 20 seconds after operating any of the functions.	<ul style="list-style-type: none"> <li>Release all controls and then operate the controls again.</li> </ul>
ERR	30B	Pre-operation check error	Sensor error occurred in the pre-operation checks.	<ul style="list-style-type: none"> <li>Turn off the key switch and then perform the pre-operation checks again.</li> <li>If the error persists, contact AICHI or an AICHI dealer for inspections.</li> </ul>
ERR	809 819	Travel Prevented, Travel motor malfunction	Either front (drive) wheel is spinning (ie, one of the front wheels turns faster than the other); or System error occurred.	<ul style="list-style-type: none"> <li>Release all controls and then operate the controls again.</li> <li>Push in the emergency stop switch and pull it out to power cycle the machine.</li> <li>If the error persists, contact AICHI or an AICHI dealer for inspections.</li> </ul>
ERR	908 918	Battery voltage failure	Battery voltage is low.	<ul style="list-style-type: none"> <li>Turn off the key switch and recharge the battery.</li> <li>If the error persists, contact AICHI or an AICHI dealer for inspections.</li> </ul>

**NOTICE**

If any diagnostic code other than described above appears, the machine may need adjustment or repair. Contact AICHI or an AICHI dealer as soon as possible.

# Chapter 13

## Specifications

### 1. Dimensions

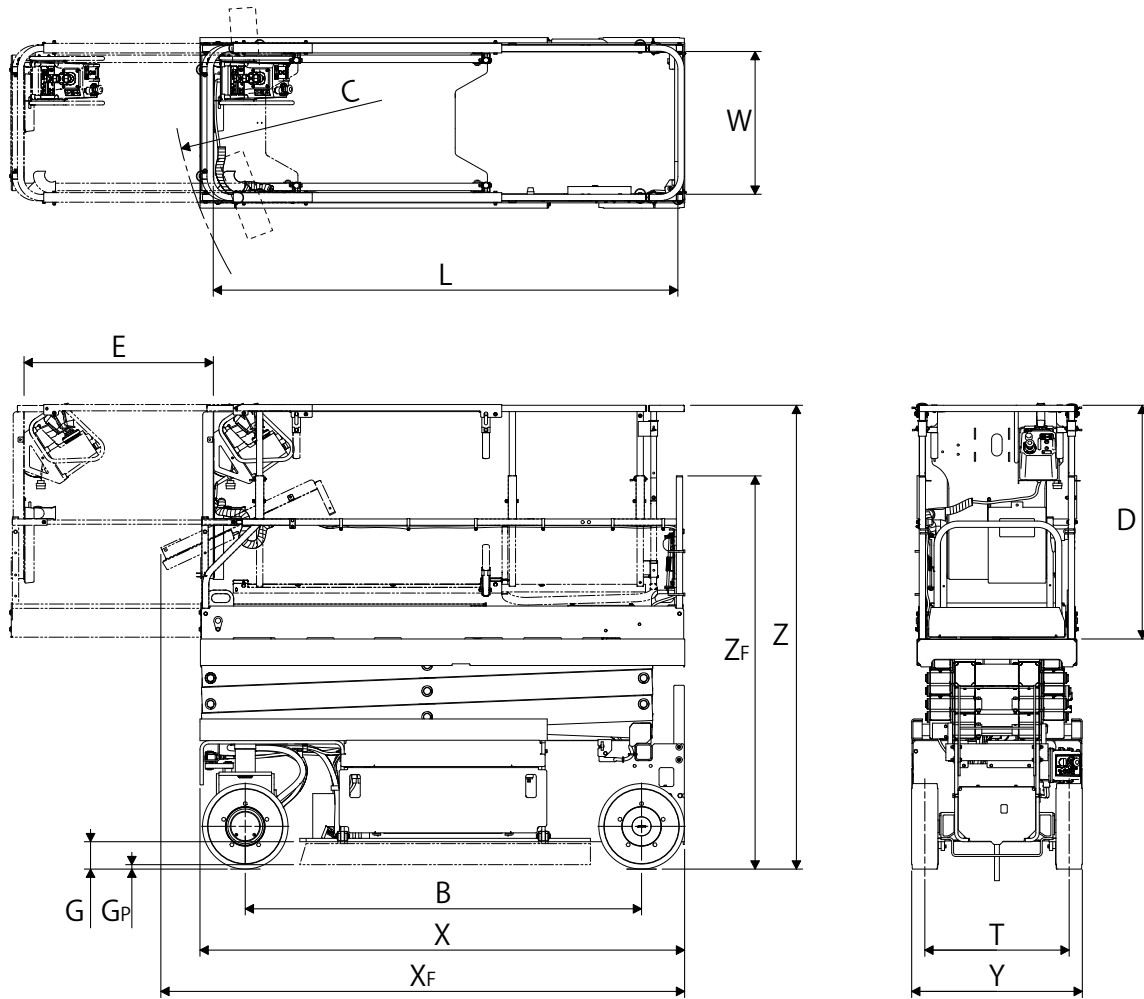

Fig. 13-1

M16X4120

- X Overall Length
- $X_F$  Overall Length with Optional Fold Down Guardrails Folded
- Y Overall Width
- Z Overall Height
- $Z_F$  Overall Height with Optional Fold Down Guardrails Folded
- G Ground Clearance (Machine Center)
- $G_P$  Ground Clearance with Pothole Protectors Deployed
- B Wheelbase
- T Tread (Front, Rear)
- L Platform Inner Length
- W Platform Inner Width
- D Platform Inner Height
- E Platform Extension Length
- C Minimum Turning Radius (Outside)

\* Above figure is SV06ENL. Other models are also similar.

## 2. General Specifications

Commercial Name / Model Code			SV06ENS / SV06E1NS	
Performance	Platform Floor Height		Max	5.72 m
			Min	0.88 m
	Platform Load Capacity (Evenly Distributed)	Total (Including Extension Deck)	Indoor	230 kg (2 persons + tools: 70 kg)
			Outdoor	230 kg (1 person + tools: 150 kg)
		Extension Deck Only		120 kg (1 person + tools: 40 kg)
	Maximum Wind Speed		Indoor	0 m/s
			Outdoor	12.5 m/s
	Maximum Allowable Tilt Angle			Front-to-Back: 3.0° Left-to-Right: 1.5°
	Maximum Travel Speeds* <sup>2</sup> (Level Surface)		Stowed	4.8 km/h
			Elevated	0.8 km/h
Platform Lift Speeds* <sup>1</sup>		Up	4.8 m / 21 – 31 s	
		Down	4.8 m / 24 – 36 s	
Gradeability* <sup>1</sup> * <sup>2</sup> (Stowed)			25 % (14°)	
Minimum Turning Radius		Inside	Zero	
		Outside [C]	1.88 m	
Measurements	Overall Length	Standard Guardrails	[X] 1.87 m	
		Fold Down Guardrails (Option)	Raised [X]	1.87 m
			Folded [X <sub>F</sub> ]	2.06 m
	Overall Width		[Y]	0.81 m
	Overall Height	Standard Guardrails	[Z]	1.99 m
		Fold Down Guardrails (Option)	Raised [Z]	1.99 m
			Folded [Z <sub>F</sub> ]	1.65 m
	Ground Clearance	Pothole Protectors	Stowed [G]	130 mm
			Deployed [G <sub>P</sub> ]	20 mm
	Wheelbase		[B]	1.51 m
	Tread (Front, Rear)		[T]	0.71 m
	Platform Inner Dimensions	Standard Guardrails	[LxWxD]	1.77 x 0.68 x 1.11 m
		Fold Down Guardrails (Option)	[LxWxD]	1.77 x 0.68 x 1.11 m
Extension Length		[E]	0.90 m	
Tires (Diameter x Width)			323 x 100 mm	
Weight* <sup>3</sup>	Gross Weight		1,540 kg	
	Maximum Tire Loading Force		700 kg	
Power source	AC Motor Power Output (Travel)		1.0 kW (JIS)	
	DC Motor Power Output (Platform Lift, Steering)		2.0 kW (JIS)	
	Battery Model		Trojan T105	
	Battery Capacity		185 Ah	
	Battery Voltage		6 V x 4	
	Charger	Charging Method		Fixed Current, Fixed Voltage
		Input Voltage		AC 100 – 240 V
		Frequency		45 – 65 Hz
Maximum Output Current		25 A		
System Voltage		DC 24 V		
Rated Hydraulic Pressure		17.2 MPa (175 kgf/cm <sup>2</sup> )		
Hydraulic Oil Tank Capacity		3.5 L		

- This machine is intended for both indoor and outdoor use.
- Advisable atmospheric temperature range: -20°C to +40°C

\*<sup>1</sup> Function speeds and gradeability assume there is 1 person on the platform and the battery is fully charged.

\*<sup>2</sup> Travel speed and gradeability are subject to surface conditions and sufficient traction.

\*<sup>3</sup> Weight information is approximate and does not incorporate different option configurations.

## General Specifications (Continued)

Commercial Names / Model Codes				SV06ENL / SV06E1NL	SV08ENL / SV08E1NL	
Performance	Platform Floor Height		Max	6.10 m	7.77 m	
			Min	1.095 m	1.215 m	
	Platform Load Capacity (Evenly Distributed)	Total (Including Extension Deck)	Indoor	Platform to 6.10m	360 kg (2 persons + tools: 200 kg)	
				Platform to 7.77 m	—	230 kg (2 persons + tools: 70 kg)
			Outdoor	Platform to 6.10m	230 kg (1 person + tools: 150 kg)	
				Platform to 7.77 m	—	(Indoor use only)
	Extension Deck Only			120 kg (1 person + tools: 40 kg)		
	Maximum Wind Speed		Indoor	0 m/s		
			Outdoor	12.5 m/s	(Indoor use only)	
	Maximum Allowable Tilt Angle			Front-to-Back: 3.0° Left-to-Right: 1.5°		
	Maximum Travel Speeds* <sup>2</sup> (Level Surface)		Stowed	4.5 km/h		
			Elevated	0.8 km/h		
	Platform Lift Speeds* <sup>1</sup>		Up	5.0 m / 22 – 34 s	6.6 m / 26 – 40 s	
			Down	5.0 m / 32 – 48 s	6.6 m / 29 – 45 s	
Gradeability* <sup>1</sup> * <sup>2</sup> (Stowed)			25 % (14°)			
Minimum Turning Radius		Inside	Zero			
		Outside [C]	2.25 m			
Measurements	Overall Length	Fold Down Guardrails	Raised [X]	2.30 m		
			Folded [X <sub>F</sub> ]	2.485 m		
			[Y]	0.81 m		
	Overall Height	Fold Down Guardrails	Raised [Z]	2.205 m	2.325 m	
			Folded [Z <sub>F</sub> ]	1.865 m	1.99 m	
	Ground Clearance	Pothole Protectors	Stowed [G]	130 mm		
			Deployed [G <sub>P</sub> ]	20 mm		
	Wheelbase		[B]	1.88 m		
	Tread (Front, Rear)		[T]	0.685 m		
	Platform Inner Dimensions	Fold Down Guardrails	[LxWxD]	2.205 x 0.68 x 1.11 m		
Extension Length		[E]	0.90 m			
Tires (Diameter x Width)			406 x 125 mm			
Weight* <sup>3</sup>	Gross Weight		1,965 kg	2,100 kg		
	Maximum Tire Loading Force		830 kg			
Power source	AC Motor Power Output (Travel)		1.0 kW (JIS)			
	DC Motor Power Output (Platform Lift, Steering)		2.0 kW (JIS)			
	Battery Model		Trojan T105			
	Battery Capacity		185 Ah			
	Battery Voltage		6 V x 4			
	Charger	Charging Method		Fixed Current, Fixed Voltage		
		Input Voltage		AC 100 – 240 V		
		Frequency		45 – 65 Hz		
Maximum Output Current		25 A				
System Voltage		DC 24 V				
Rated Hydraulic Pressure		17.2 MPa (175 kgf/cm <sup>2</sup> )				
Hydraulic Oil Tank Capacity		5.7 L				

• SV06ENL is intended for both indoor and outdoor use. SV08ENL is intended for indoor use only.

• Advisable atmospheric temperature range: -20°C to +40°C

\*<sup>1</sup> Function speeds and gradeability assume there is 1 person on the platform and the battery is fully charged.

\*<sup>2</sup> Travel speed and gradeability are subject to surface conditions and sufficient traction.

\*<sup>3</sup> Weight information is approximate and does not incorporate different option configurations.

## General Specifications (Continued)

Commercial Names / Model Codes			SV08EWL / SV08E1WL	SV10EWL / SV10E1WL			
Performance	Platform Floor Height		Max	7.92 m	9.68 m		
			Min	1.215 m			
	Platform Load Capacity (Evenly Distributed)	Total (Including Extension Deck)	Indoor	Platform to 7.92 m	450 kg (2 persons + tools: 290 kg)		
				Platform to 9.68 m	—	320 kg (2 persons + tools: 160 kg)	
			Outdoor	Platform to 7.92 m	120 kg (1 person + tools: 40 kg)		
				Platform to 9.68 m	—	320 kg (1 person + tools: 240 kg)	
	Extension Deck Only			120 kg (1 person + tools: 40 kg)			
	Maximum Wind Speed		Indoor	0 m/s			
			Outdoor	12.5 m/s			
	Maximum Allowable Tilt Angle			Front-to-Back: 3.0° Left-to-Right: 2.0°			
Maximum Travel Speeds* <sup>2</sup> (Level Surface)		Stowed	4.0 km/h				
		Elevated	0.8 km/h				
Platform Lift Speeds* <sup>1</sup>		Up	6.7 m / 32 – 48 s	8.5 m / 44 – 66 s			
		Down	6.7 m / 40 – 60 s	8.5 m / 48 – 72 s			
Gradeability* <sup>1</sup> * <sup>2</sup> (Stowed)			25 % (14°)				
Minimum Turning Radius		Inside	Zero				
		Outside [C]	2.58 m				
Measurements	Overall Length	Fold Down Guardrails	Raised [X]	2.50 m			
			Folded [X <sub>F</sub> ]	2.685 m			
	Overall Width		[Y]	1.17 m			
	Overall Height	Fold Down Guardrails	Raised [Z]	2.325 m			
			Folded [Z <sub>F</sub> ]	1.99 m			
	Ground Clearance	Pothole Protectors	Stowed [G]	130 mm			
			Deployed [G <sub>P</sub> ]	20 mm			
	Wheelbase		[B]	2.08 m			
	Tread (Front, Rear)		[T]	1.045 m			
	Platform Inner Dimensions	Fold Down Guardrails	[LxWxD]	2.405 x 1.035 x 1.11 m			
Extension Length		[E]	1.27 m				
Tires (Diameter x Width)			406 x 125 mm				
Weight* <sup>3</sup>	Gross Weight		2,770 kg	2,960 kg			
	Maximum Tire Loading Force		1,100 kg				
Power source	AC Motor Power Output (Travel)		1.0 kW (JIS)				
	DC Motor Power Output (Platform Lift, Steering)		2.0 kW (JIS)				
	Battery Model		Trojan T105				
	Battery Capacity		185 Ah				
	Battery Voltage		6 V x 4				
	Charger	Charging Method		Fixed Current, Fixed Voltage			
		Input Voltage		AC 100 – 240 V			
		Frequency		45 – 65 Hz			
Maximum Output Current		25 A					
System Voltage		DC 24 V					
Rated Hydraulic Pressure		17.2 MPa (175 kgf/cm <sup>2</sup> )					
Hydraulic Oil Tank Capacity		5.7 L					

• These machines are intended for both indoor and outdoor use.

• Advisable atmospheric temperature range: -20°C to +40°C

\*<sup>1</sup> Function speeds and gradeability assume there is 1 person on the platform and the battery is fully charged.

\*<sup>2</sup> Travel speed and gradeability are subject to surface conditions and sufficient traction.

\*<sup>3</sup> Weight information is approximate and does not incorporate different option configurations.

### 3. Supplementary Information

The following information is provided as supplementary information for the machine.

- The A-weighted emission sound pressure level at platform does not exceed 70 dB(A).
- The vibration total value to which the hand-arm system is subjected does not exceed 2.5 m/s<sup>2</sup>.
- The highest root mean square value of weighted acceleration to which the whole body is subjected does not exceed 0.5 m/s<sup>2</sup>.

# Appendix A

## Test Report

### 1. Static Test (EN280; 6.1.4.2.1)

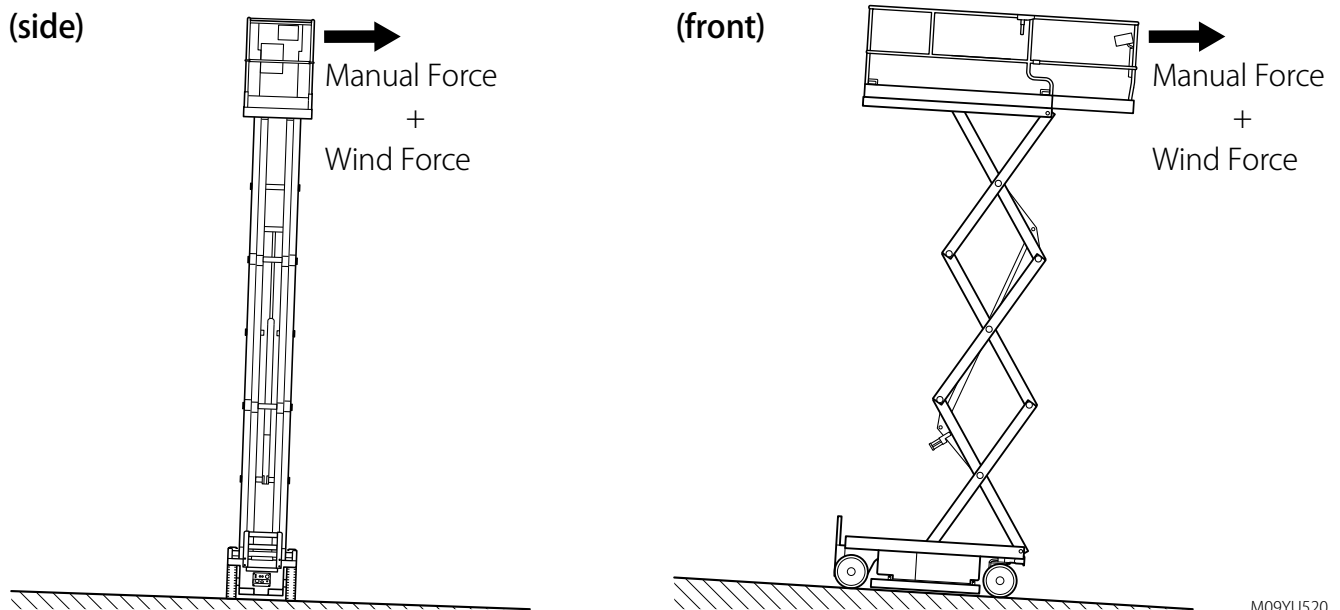

Fig. A-1

#### 1-1 SV06ENS

Test conditions	Accordance with EN280	Weather conditions	Outdoor; no wind
Result	All tests passed		

#### 1-2 SV06ENL

Test conditions	Accordance with EN280	Weather conditions	Outdoor; no wind
Result	All tests passed		

#### 1-3 SV08ENL

Test conditions	Accordance with EN280	Weather conditions	Indoor
Result	All tests passed		

#### 1-4 SV08EWL

Test conditions	Accordance with EN280	Weather conditions	Outdoor; no wind
Result	All tests passed		

#### 1-5 SV10EWL

Test conditions	Accordance with EN280	Weather conditions	Outdoor; no wind
Result	All tests passed		

## 2. Dynamic Test (EN280; 6.1.4.2.2)

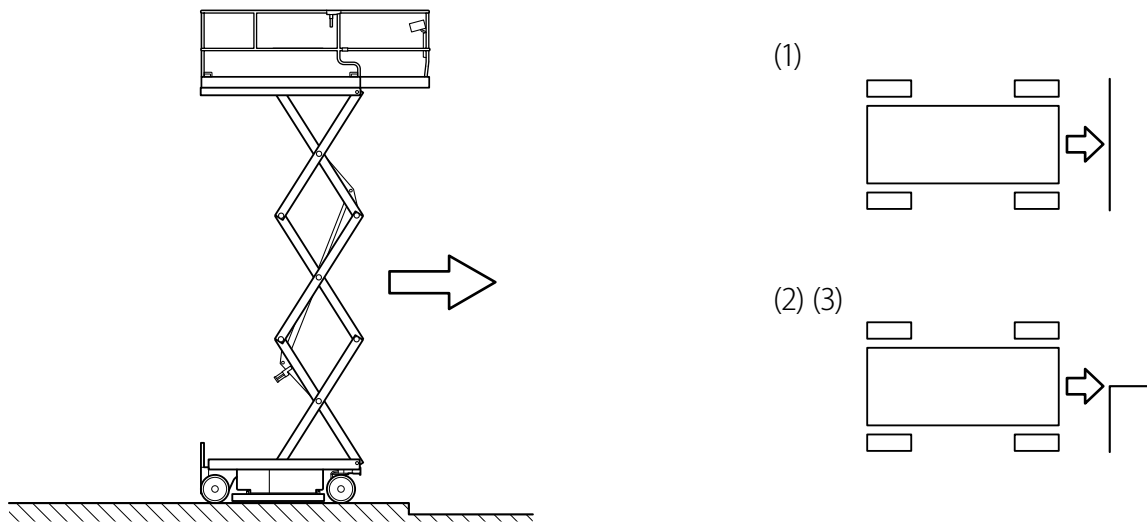

Fig. A-2

M09YU622

- (1) Both leading wheels into the gap
- (2) One leading wheel into the gap
- (3) One leading wheel into the gap (backwards)

### 2-1 SV06ENS

**Result: all tests passed**

(nominal load: 230 kg / 50% of platform; drive speed: 0.9 km/h (= 0.8 + 0.1 tolerance); 0.25 m/s)

### 2-2 SV06ENL

**Result: all tests passed**

(nominal load: 360 kg / 50% of platform; drive speed: 0.9 km/h (= 0.8 + 0.1 tolerance); 0.25 m/s)

### 2-3 SV08ENL

**Result: all tests passed**

(nominal load: 230 kg / 50% of platform; drive speed: 0.9 km/h (= 0.8 + 0.1 tolerance); 0.25 m/s)

### 2-4 SV08EWL

**Result: all tests passed**

(nominal load: 450 kg / 50% of platform; drive speed: 0.9 km/h (= 0.8 + 0.1 tolerance); 0.25 m/s)

### 2-5 SV10EWL

**Result: all tests passed**

(nominal load: 320 kg / 50% of platform; drive speed: 0.9 km/h (= 0.8 + 0.1 tolerance); 0.25 m/s)



## *Appendix B*

# **Declaration of Conformity**

# EC DECLARATION OF CONFORMITY

## AICHI CORPORATION

Product: Mobile Elevating Work Platform

Models: SV06ENS/SV06ENL/SV08ENL  
SV08EWL/SV10EWL

Serial Number: \*\*\*\*\*

Manufacturer: Aichi Corporation  
1152-10, Aza Yamashita Ryoke Oaza Ageo-shi,  
Saitama 362-8550  
Japan

Technical File: AICHI Sales Office BV  
Florijnstraat 4, 4903 RM Oosterhout,  
The Netherlands

Contact: R. van Gent / President

Notified body of EC type-examination:  
SGS Nederland B.V.  
Malledijk 18 P.O.Box 200 NL-3200 AE Spijkenisse  
The Netherlands  
Identification number Notified Body: 0608

Certificate Number: 110201/500/001/3014

The above products have been evaluated for conformity with provisions of following European Directives:

Directive 2006/42/EC Machinery Directive  
Directive 2014/30/EC EMC Directive

Applied Harmonized Standards:  
EN 280: 2013+A1: 2015  
EN 13309: 2010

Name: Takashi Kimura  
Position: Director Development Division  
Place: Ageo-shi, Japan  
Date: 30 November 2017

This declaration conforms with the requirements of annex II-A of the council directive.  
Any modification to the above described machine violates the validity of this declaration.

## Appendix C

# Daily Inspection Check Sheet

### **NOTICE**

**Make a copy of the daily inspection check sheet before performing the pre-operation checks.**

Inspect each item in accordance with the pre-operation check procedure described in this manual.

Make a check in the appropriate box on the daily inspection check sheet depending on the inspection result.

